

DEPARTMENT
OF THE ARMY TECHNICAL MANUAL

OPERATOR, ORGANIZATIONAL, DIRECT SUPPORT
AND GENERAL SUPPORT MAINTENANCE
MANUAL INCLUDING REPAIR PARTS LIST
FOR

SAW, BAND
METAL CUTTING
Model S87
(DON G. JENNESS CO., INC.) (3405-00-294-9591)

HEADQUARTERS,
DEPARTMENT OF THE ARMY

NOVEMBER 1980

**OPERATOR'S, ORGANIZATIONAL, DIRECT SUPPORT
AND GENERAL SUPPORT MAINTENANCE MANUAL
INCLUDING REPAIR PARTS LIST
FOR
SAW, BAND
METAL CUTTING
MODEL S 87
(NSN 3405-00-294-9591)**

REPORTING ERRORS AND RECOMMENDING IMPROVEMENTS You can help improve this manual. If you find any mistakes or if you know of a way to improve the procedures, please let us know. Mail your letter. DA Form 2028 (Recommended Changes to Publications and Blank Forms); or DA Form 20282, located in the back of this manual direct to: Commander, US Army Armament Materiel Readiness Command, ATTN: DRSAR-MAS, Rock Island, IL 61299. A reply will be furnished directly to you.

NOTE

This manual is published for the purpose of identifying an authorized commercial manual for the use of the personnel to whom this band saw is issued.

Manufactured by: Don G. Jenness Co., Inc.
3010 East Olympic Boulevard
Los Angeles, CA 90023

Procured under Contract No. DAAA09-76-C-6822

This technical manual is an authentication of the manufacturers' commercial literature and does not conform with the format and content specified in AR 310-3, Military Publications. This technical manual does, however, contain available information that is essential to the operation and maintenance of the equipment.

INSTRUCTIONS FOR REQUISITIONING PARTS

NOT IDENTIFIED BY NSN

When requisitioning parts not identified by National Stock Number, it is mandatory that the following information be furnished the supply officer.

- 1- Manufacturer's Federal Supply Code Number - 6G374
- 2 - Manufacturer's Part Number exactly as listed herein.
- 3 - Nomenclature exactly as listed herein, including dimensions, if necessary
- 4 - Manufacturer's Model Number - Model S87
- 5 - Manufacturer's Serial Number (End Item)
- 6 - Any other information such as Type, Frame Number, and Electrical Characteristics, if applicable.
- 7 - If DD Form 1348 is used, fill in all blocks except 4, 5, 6, and Remarks field in accordance with AR 725-50.

Complete Form as Follows:

- (a) In blocks 4, 5, 6, list manufacturer's Federal Supply Code Number - 6GA74 followed by a colon and manufacturer's Part Number for the repair part.
- (b) Complete Remarks field as follows:
Noun: (nomenclature of repair part)
For: NSN: 3405-00-294-9591
Manufacturer: Don G. Jenness Co., Inc.

Model: S87
Serial: (of end item)

Any other pertinent information such as Frame Number,
Type, Dimensions, etc.

iii (iv blank)

OPERATING INSTRUCTIONS

AND

PARTS LIST

FOR

SAW, BAND

METAL CUTTING

BAND SAW SAFETY INSTRUCTIONS

1. Read, understand, and follow the safety and operating instructions found in this manual. Know the limitations and hazards associated with this band saw. A safety rules decal is installed on each machine to serve as a reminder of basic safety practice.
2. Grounding the band saw: Make certain that the machine frame is electrically grounded and that a grounding lead is included in the incoming electrical service. In cases where a cord and plug are used, make certain that the grounding lug connects to a suitable ground. Follow the grounding procedure indicated by the National Electric Code.
3. Safety: Wear an approved safety shield, goggles, or glasses to protect eyes when operating the band saw:
4. Personal Protection: Before operating the machine, remove tie, rings, watch and other jewelry and roll up sleeves above the elbow. Remove all loose outer clothing and confine long hair. Hearing protectors should be used where noise exceeds the level of exposure allowed in Section 1910.95 of the OSHA regulations. Do not wear gloves.
5. Work Area: Keep the floor around the machine clean and free of scrap material, chips, oil, grease, coolant, tools or accessories to minimize the danger of slipping or tripping. Be sure the table is free of all scrap, foreign material and tools before starting a cut. Anti-skid floor strips are recommended on the floor area where the operator normally stands. Each machine work area should be marked off. Make certain the work area is well lighted and ventilated. Where dust or fumes present a hazard, provide proper exhaust system. Provide for adequate work space around the machine.
6. : Keep the machine guards in place at all times when the machine is in use. If removed for maintenance purposes, use extreme caution and replace the guards on completion of the-maintenance task before using the band saw./

DO NOT OPERATE THE MACHINE WITH THE GUARDS OFF!

7. not Overreach: Maintain a balanced stance and keep your body under control at all times. Do not overreach.
8. Blades that are in Good Condition: Blades that are not sharp or having missing teeth can re-quire excessive force or could break. Examine the backs of the blades. If it is rolled over, do not use the blade. Do not exceed 500 SFM using high speed steel blade.
9. Safety: Keep hands away from the blade while it is in motion. Always adjust the guide bar to be as close to the top of the work piece or fixture as possible to minimize blade exposure. Do not open the upper or lower band saw door while machine is under power. Do not position hand on stock in line with the band saw blade.
10. Wheel Rotation: Be sure the band saw wheels rotate clockwise when under power.
11. Machine Adjustments: Make all adjustments with power off except wheel speed and feed rate.
12. Machine Capacity: Do not make any cuts requiring-more power than is available on the machine. Do not exceed table carrying capacity of 500 lbs. evenly distributed.
13. Avoid Accidental Starts: Make certain the motor switch is in the "off" position before connecting power to the band saw.
14. Careless Acts: Give the work you are doing your undivided attention. Looking around, carrying on a conversation and "horseplay" are careless acts that can result in serious injury.
15. Job Completion: If the operator leaves the machine area for any reason, the hand saw should be turned off and come to a complete stop before his departure. In addition, if the operation is complete, he should clean the band saw and work area Never clean tile machine with the power on and never use the hand; to clear chips or sawdust; use a brush.
16. Disconnect Machine: Before performing any service c: maintenance and when changing blades disconnect machine from power source.

- 17. Replacement Parts: Use only authorized replacement parts and accessories.
- 18. Misuse: Do not use this saw for other than its intended purpose.

Do not equip your saw with a motor larger than 3 HP at 1800 RPM.

MACHINE SPECIFICATIONS

Table Size-----	24" (609mm) x 24" (609mm)
Table Tilt-----	450R. - 15°L.
Throat, Blade to Column Guard -----	19-3/4" (501 mm)
Maximum Work Thickness. -----	12" (305mm)
Table Feed Force (optional) -----	0-60 lbs. (0-27.2 kg.)
Speed Range:	
Low (infinitely variable) -----	47-470 rpm
High (infinitely variable)-----	520-5200 rpm
Blade Width Capacity -----	1/8" - 1" (3 - 25mm)
Blade Length-----	149" - 152" (3785 -3861mm)
Upper Wheel Adjustment -----	1/2" - (38mm)
Band Saw Wheel Diameter -----	20" (508 mm)
Main Drive Motor -----	2 or 3 HP (1.5 kw or 2.24 kw)
Weight Domestic Crated -----	1300 lbs. (590 kg)

BELTS

<u>LOCATION</u>	<u>PART NO</u>	<u>INDUSTRY NO.</u>	<u>NO. REQ.</u>
Between variable pulleys -----	6077143 -----	1922V426	--- 1
Between countershaft and transmission	6077141 -----	7M1180	--- 3
Between compressor and motor --	607707G -----	7M710	--- 1

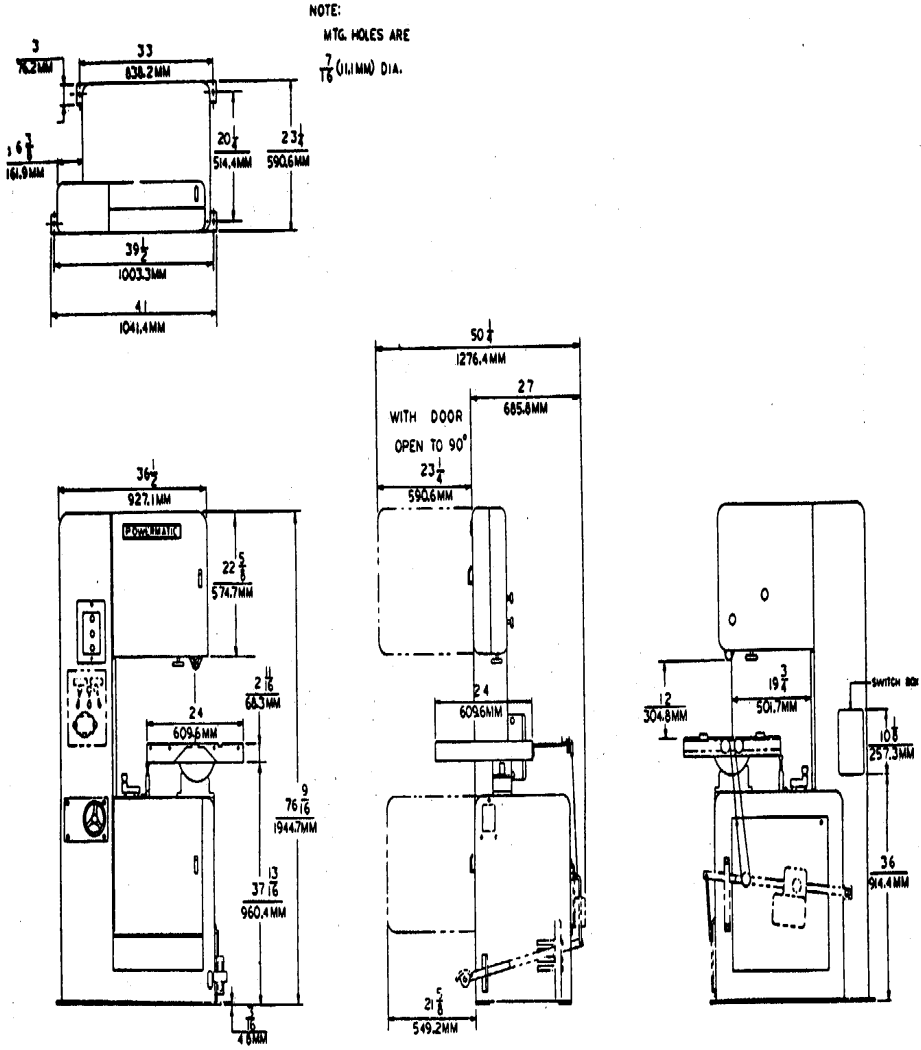

Figure 1. Foundation Layout.

LUBRICATION CHART

ITEM NO	INTERVAL	ITEM& INSTRUCTIONS	RECOMMENDED LUBRICANT
1	Weekly	Variable Speed Sheaves - oil male hubs	SAE No. 10
2	Weekly	Air Compressor - on side	SAE No. 10
3	Monthly	Variable Speed Adjusting Screw	Fiske Co., Lubriplate No. 630A
4	Monthly	Band Tensioning Screw	Fiske Co., Lubriplate No. Lubriplate
5	Monthly	Upper Wheel Slide	Fiske Co., Lubriplate No. 630A
6	Monthly	Variable Speed A	SAE No. 10
7	Monthly	Transmission. Fill Through Fill Plug (drain and Flush ever six months)	Mobil Vactra No. 1
8	Monthly	Upper Wheel Tilt Bracket Pivot Screws and adjusting screw	SAE No. 10
9	Monthly	Table Trunnion Surfaces, clean & regrease	Fiske Co., Lubriplate No. 630A
10	Monthly	Gearbox Shifter Detent Plunger	SAE No. 10
11	Monthly	Guide Post & Guide Post Clamp Screw	SAE No. 10
12	6 Months	Speed Dial Gears	Fiske Co., Lubriplate No. 630A

LOCATION PLANNING

Caution: Lift machine with fork lift truck under base. Do not lift through the throat opening. Net weight is 1100 lbs. (498.96kg), approximately. The machine should be located so that space is allowed for easy feeding and removal of material. Clearance should also be allowed behind the machine for servicing and in front for the opening of doors (fig. 1).

RECEIVING

Remove all protective coverings, crating, etc. carefully. Inspect the machine for broken or damaged parts. Any evidence of damage in transit should be reported immediately. Four (4) holes are provided in the base for anchoring the machine to the floor.

Level the table and check to see that post is square to the table. Connect the leads of the line circuit into the starter on the back of the machine and check for proper direction of rotation as follows:

1. into low range on transmission. To do this, manually rotate the bottom wheel, at the same time move shift lever to the left detent position.
2. start button to start main drive motor and check rotation. The lower wheels should rotate clockwise. not, disconnect machine from power source and change any two incoming leads in the starter usually mounted on the rear of the column of machine. Install a saw band and check to see that the band touches upper and lower backup bearings in saw guide and is centered on both top and bottom wheels. If it is not centered, see section on band saw lineup for proper

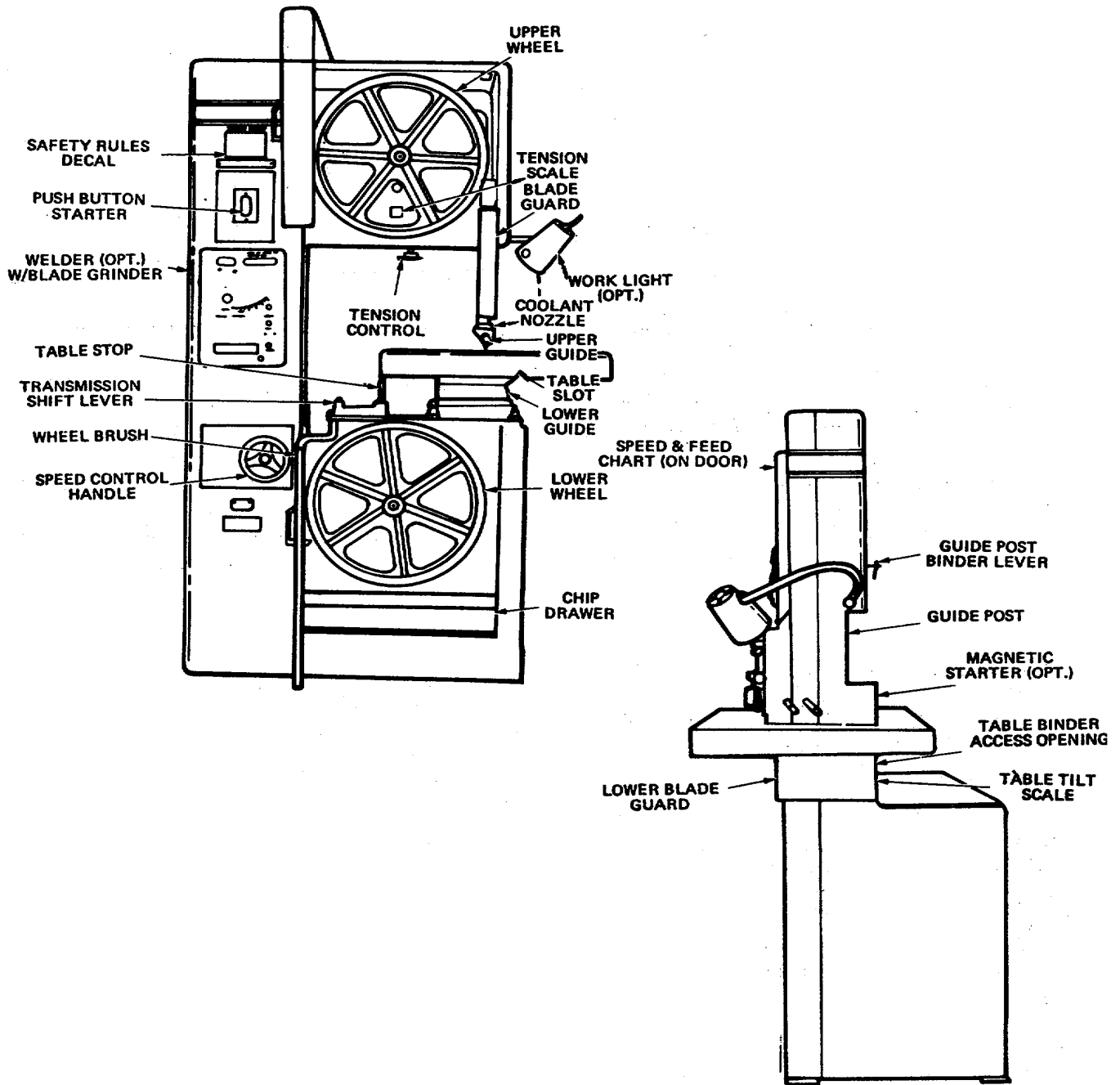

Figure 2. Features and Controls.

FEATURES AND CONTROLS (FIG. 2)

SPEED AND FEED CHART: The speed and feed chart mounted on the upper door of the saw enables the operator to quickly select the correct saw band, speed and feed rate on the chart for basic materials

TABLE: A heavy duty table and trunnion assembly will hold 200 lbs (91.72kg) at any point or 500 lbs (226.8kg) evenly distributed. The table can be tilted 150 left or 450 right. Pointer and degree scale are attached directly to the trunnion and cradle to indicate the angle at which the table is set.

SAW WHEELS: The wheels are cast iron, dynamically balanced, centered and aligned so that the band will run at all times against backup bearings and centered on wheels. Tires are vulcanized to the wheels assuring no slippage and long wear. Should the tires become worn, there is an exchange policy where the wheels are returned for credit after the replacement wheels are received. To remove a wheel, loosen both setscrews and pull straight out. If the wheel has been in place for a long time, a wheel puller may be necessary. On replacement be sure to oil the shaft and hole to avoid rusting.

SPEED CONTROL: Variable speeds are selected through a column-mounted control wheel. An easy to change, easy to set shift lever is mounted on the cross member near the table. In low range, speeds are from 47 to 470 SFM (14.33 to 143.3 mpm) and in high range, from 520 to 5200 SFM (158.5 to 1585mpm). A speed dial is mounted on the column of the machine for direct reading of surface feet per minute (meters per minute). If the shift lever will not go into the detent position when changing range, rotate the lower wheel manually until teeth engage.

WHEEL BRUSHES: Check the wheel brushes occasionally. If they are worn so that they no longer contact the wheel face, loosen the adjusting screws and move the brush up to the wheel. Replace as required.

TRANSMISSION: Drain, flush, and refill after first month and thereafter at least every six months. Capacity is 3 quarts. Fill to the top of fill pipe, but do not over fill. Check for seal leaks around the shafts. Any rough operation, vibration, loud or unusual noises should be investigated immediately. It is recommended that the transmission be returned to the factory for repairs, or that repairs be made by a factory serviceman.

CAUTION: Difficulties in shifting may be caused by wear or incorrect adjustment in the shifting linkage and this should be considered before repairing the transmission. It may be necessary to jog the band drive motor until the shift lever is fully engaged, Do not attempt to force the shift lever into position. **VARIABLE SPEED PULLEY:** Every six months remove the pulley unit, and wash and clean with solvent. Re-oil and install. Check the variable pulley faces for scoring which could damage the belts.

BLADE INSTALLATION

NOTE: If the blade width to be installed is less than 1/2", use the 3/16" thick shim back of the upper guide and turn the step in the bar support for the lower guide towards the trunnion. Check the inserts for the correct width. The insert width should be slightly less than the distance from the back of the band to the bottom of the gullet. Change them if required and leave them pulled away from the band. Lower the upper wheel housing. Loosen both the insert clamp screws and remove the insert. Open both doors and post-mounted band guard. Loop the band over the upper wheel, feed it into the blade guard on the column and under the lower wheel. Using the band tension handwheel, put tension on the blade. Rotate the wheels by hand and watch how the band tracks on the wheels. Tilt the wheel if necessary to cause the band to run centered on the wheel. Check to see if the blade is against the upper and lower guide backup bearing. For proper operation the blade should be in firm contact with lower backup bearing and be in light contact or slightly clearing the upper backup bearing. If it is not, see section on band saw alignment and realign the machine.

BLADE INSTALLATION (continued)

Increase tension to the setting for the blade width to be used. Slide one insert on each guide to be lightly against the blade and lock in position. Slide the other insert against the blade to give a slight drag and lock in position. Check this by pulling out on the band and checking the feel of the slight drag. Close the guide bar mounted blade guard and both doors before starting the band saw.

TABLE AND BELT ADJUSTMENTS

TABLE STOP ADJUSTMENT: The table stop is factory set to position the table square with the blade and should not need adjustment. However, if the band saw is realigned for any reason, it will be necessary to reset the stop. Unlock the jam nut and screw the jackscrew a few turns down into the bracket so as to allow the table to go past the 0° point. Adjust the guide bar to be close to the table with the trunnion unlocked and with a combination square, or similar gauge set on the table with the blade against the post; adjust the table to be square with the post using the jackscrew in the stop bracket. Relock the jam nut, swing the table away from and then back to the stop. Tighten the trunnion lock. Recheck to see if the table is still square with the guide post. Readjust if necessary. Check the position of the scale pointer and reposition if necessary (fig. 3).

BELT ADJUSTMENT: Shift the transmission into its neutral position. Remove the rear cover. The belts from the transmission to the countershaft can be tightened by means of a jackscrew in a lug welded to the upper shelf. With the four mounting screws snug but not tight, jack the countershaft bracket until the three belts between the transmission and countershaft are properly adjusted. The type of belt used must be guitar string tight to operate properly (fig. 4).

The variable speed belt must be adjusted after the above belts are and must be readjusted whenever the above belts are readjusted. Loosen the stops on the speed control screw and move them away from the operating nut. Turn saw motor on and adjust speed control handle until the variable speed belt either bottoms out in the motor pulley or is flush with the outside diameter of the countershaft pulley. If the belt bottoms out before becoming flush with the outside diameter, raise the motor by adjusting the motor base with the jackscrew nuts. Continue raising the motor base and adjusting the speed control until the belt is flush with the outside diameter of the countershaft pulley and just slightly before bottoming out on the motor pulley. If belt is flush with countershaft pulley outside diameter and has not bottomed out, squeeze the belts halves together or pull out on the belt to cause the spring loaded side of the motor pulley to move back and lower the motor base until the belt is close to bottoming out on the motor pulley hub. Set the low speed stop on the speed adjusting nut and lock in place. Check the position of the information on the dial to see if the low speeds 47 and 620 line up with the pointer. If it does not, loosen the nut on the speed control handwheel shaft and push the shaft forward until the gearing disengages and the speed dial spins free. Adjust dial so that the low speeds 47 and 520 line up with the pointer. Retighten nut on the end of the speed control shaft making certain by rocking the dial that it is lined up to the nearest tooth and that the gears re-engage.

If the saw is equipped with an optional chip blower, belt tension is achieved by use of a jackscrew and jam nut working through an ear welded to the lower shelf. Back off on the jackscrew to install the belt and use it to tension the belt once it is installed. The type of belt used requires that it be guitar string tight for proper drive.

BELT ADJUSTMENTS(continued)

CAUTION: Make all adjustments except changing speed with the motor off. Adjust speed control handle to increase the speed until the variable speed belt is flush with the outside diameter of the motor pulley. Set the variable speed stop against the adjusting nut and lock in place. Put the rear cover back on.

BAND SAW ALIGNMENT

One of the most important keys to successful band sawing is the lineup of the saw. Your machine as received should be properly lined up ready to do your sawing operations. However, if it is not lined up or because of wheel wear or wheel replacement alignment has been disturbed, listed below are the steps to go through to realign the saw.

1. the distance from the column face to the lower wheel centerline. It should be 10-5/8". If it is not, loosen the four mounting screws bolting the transmission to the shelf and re-position it to the above dimension. Snug the screws down.
2. the parallelism of the lower wheel to the cross member with a combination square. It should be parallel within 1/32". Make sure also that the lower wheel is not all the way back against the shoulder on the transmission shaft. Allow approximately 1/8" for final adjustments. Check also that the wheel clears the chip brush bracket.
3. the location of the guide bar in the upper wheel housing. It should be 20-1/8" from the column over it's entire length. If it is not, the guide bar bracket will have to be relocated. Back off the two setscrews at the right hand side of the bracket and then loosen four mounting screws bolting the bracket to the upper frame. The two jackscrews in the welded ears below the bracket can be used to tip the bracket into parallelism with the column. If the guide bar is parallel but out of location, simply slide it over to get the 20-1/8" location for the full length of the bar. Snug down the three bracket mounting screws nearest to the adjusting jacks.
4. the location of the upper wheel centerline. It should be 10-5/8" from the column face. Readjust if necessary by using the, opposing jackscrews in the upper wheel slide on each side of the wheel bracket. Leave enough clearance between the screws so that the bracket can pivot freely. Remove the table from the trunnion. Note any shims used and put the shims under the same screws when the table is reinstalled.
5. a 3/8" width blade. Check the upper guide. It should be mounted to the guide bar with a 3/16" shim. Check the lower guide bracket. The step should face away from the front of the machine. With a long straight edge, check for parallelism of the wheels tilting the upper wheel and moving it on its shaft to check for parallelism. Note lower wheel may not be properly tilted causing the upper wheel to be too far back or forward. Adjust the lower wheel if required using the setscrews in the transmission mounting feet to tilt the lower wheel. If one side of the wheels is parallel and the other is not parallel, pivot the upper wheel housing with the jacking studs provided. Be careful not to lose the position of the wheel centerline and post location. After paralleling the wheels, spin the wheels clockwise and adjust the tilt to track the band in the center of both wheels. If the band can be centered on the upper wheel but is off center on the lower wheel, make sure the guides are not holding the band from centering. If they are, temporarily remove them. Spin the wheels counter-clockwise. The band should track the same in both directions if the wheels are parallel. If it does not track the same in both directions, parallelism of the wheels must be corrected.
6. the upper guide if it was removed. Note the position of the blade relative to the wheel. If it is against the guide backup bearing and will not allow the blade to center, the up- per wheel must be moved out. If it clears the backup bearing, the wheel will have to be moved

BAND SAW ALIGNMENT (continued)

back. Adjust the guide bar up and down and note whether the backup bearing and guide bar are parallel to the back of the band. If it is not, the bracket will have to be adjusted with the jackscrews to bring the post into line with the band. Check also on the side parallelism of the side of the guide bar to the band. With one of the inserts slightly clearing the band and the other well clear of the band, raise the guide post up and down to see if it moves parallel with the band. If it is not parallel, the bracket must be pivoted into alignment using the bottom jackscrews. Use care in adjusting all jackscrews so that proper locations are maintained and the wheels remain parallel. Note the back of the band should lightly contact the backup bearing over it's full travel.

7. the transmission and upper wheel bracket in place. Note prior to locking the extreme right hand screw of the upper wheel bracket, adjust the two set screws above and below it to be in light contact with the backup plate.
8. the four mounting screws holding the trunnion to the frame cross member. Reinstall the lower guide and table. Locate the trunnion so that the band overlaps the backup by approximately .093" and is centered in the insert slot. Using a combination square, check the squareness of the table to the back of the guide bar and square the table to the back of the guide post using the jackscrews provided in the trunnion support bracket. Position the trunnion so that there is good contact between the back of the band and the backup bearing. Lock the trunnion bracket to the cross member.
9. the combination square on the table and against the side of the guide post, using the table stop at the left hand side of the table, square the table sidewise to the post. Lock the stop screw with the jam nut provided.
10. Tilt the table at 450 to the right and check to be sure the band clears the insert. If it does not clear, loosen the four screws that mount the table to the trunnion and readjust the table. Re-tighten the mounting screws and recheck both the 00 and 450 points for band clearance.

TROUBLE SHOOTING AND SAWING HINTS

TROUBLE	PROBABLE CAUSE	REMEDY
Table Tilt Does Not Hold Position Load	<ol style="list-style-type: none"> 1. Tilt lock is not tightened 2. Tilt lock mechanism is broken or worn. 	<ol style="list-style-type: none"> 1. Tighten tilt lock. 2. Replace.
Table Will Not Tilt.	<ol style="list-style-type: none"> 1. Trunnion was not lubricated 2. Trunnion is jammed 	<ol style="list-style-type: none"> 1. Lubricate. 2. Disassemble and replace jammed parts.
Table Vibration (while sawing).	<ol style="list-style-type: none"> 1. Incorrect band speed. 2. Incorrect choice of saw band pitch. 3. Worn or improperly adjusted saw guide inserts. 4. Worn saw guide back-up bearing. 	<ol style="list-style-type: none"> 1. Check speed and feed chart and correct speed for material. 2. Check speed and feed chart and change to correct blade. 3. Adjust or replace inserts. 4. Replace backup bearings.
Transmission Will Not Stay In Gear.	<ol style="list-style-type: none"> 1. Broken roll pins in shift linkage. 2. Shift mechanism in transmission is jammed. 3. Sliding clutch jaws in transmission are jammed or damaged. 	<ol style="list-style-type: none"> 1. Replace roll pins. 2. Consult factory. 3: Consult factory.
Surface Finish On Work Tool Rough.	<ol style="list-style-type: none"> 1. Saw guide inserts are worn 2. Saw band speed is too low 3. Saw band pitch is too coarse 	<ol style="list-style-type: none"> 1. Replace inserts. 2. Increase speed. 3. Change to finer pitch blade.
Saw Band Cutting Inaccurately.	<ol style="list-style-type: none"> 1. Worn blade teeth 2. Scale on workpiece was not removed. 3. Workpiece hardened by grinding to remove scale. 4. Incorrect saw band or insert alignment. 5. Post not square to table 6. Incorrect band speed used correct band speed. 7. Incorrect feed force used 8. Saw guide on upper post not located close enough. To workpiece. 9. Incorrect choice of saw band.9 10. Incorrect saw band tension 	<ol style="list-style-type: none"> 1. Replace blade. 2. Remove scale. 3. Scrap workpiece. 4. Realign saw or inserts. 5. Square post to table. 6. Use table, and change to 7. Reduce feed force. 8. Relocate post as close as possible to top of workpiece or fixture. Use table, and change to correct band. 10. Readjust tension.
Saw Band Teeth Stripping (usually caused by chip welding).	<ol style="list-style-type: none"> 1. Saw band pitch too coarse for thin work section. 2. Work not held firmly. 3. Band speed too low. 	<ol style="list-style-type: none"> 1. Change band to finer pitch. 2. Change method of holding work. 3. Increase band speed.
	11	

TROUBLE SHOOTING AND SAWING HINTS (continued)

TROUBLE	PROBABLE CAUSE	REMEDY
Premature Saw Band Breakage (usually caused by teeth stripping.)	<ol style="list-style-type: none"> 1. Saw band speed too low 2. Feeding force too high 3. Pitch of saw band too coarse 4. Saw guide inserts and back-up bearings not properly guiding band. 5. Band tension too high 6. Defective weld instructions. 	<ol style="list-style-type: none"> 1. Increase speed. 2. Decrease feed force. 3. Change band to finer pitch: 4. Check for worn inserts and back-up ring and replace if required. 5. Reduce band tension. 6. See Welder Manual for
Premature Dulling of Saw Band Teeth	<ol style="list-style-type: none"> 1. Not breaking in saw band on first few cuts 2. Band speed too high, causing abrasion. 3. Saw band pitch too coarse 4. Feed pressure too light 5. Cutting rate too high 6. Faulty material analysis 7. Faulty material such as heavy scale, inclusions, hard spots, etc. 8. Saw band vibration. worn belt or parts. 9. Chipped tooth lodged in cut tooth. 10. Chip welding. 	<ol style="list-style-type: none"> 1. Reduce feed pressure and speed on first cuts. 2. Reduce speed. 3. Change to finer pitch blade. 4. Increase pressure. 5. Reduce feed pressure. 6. Determine material and correct speed feed or blade as required. 7. Replace material. 8. Check for unbalance due to 9. Stop cut and remove lodged 10. Reduce speed.

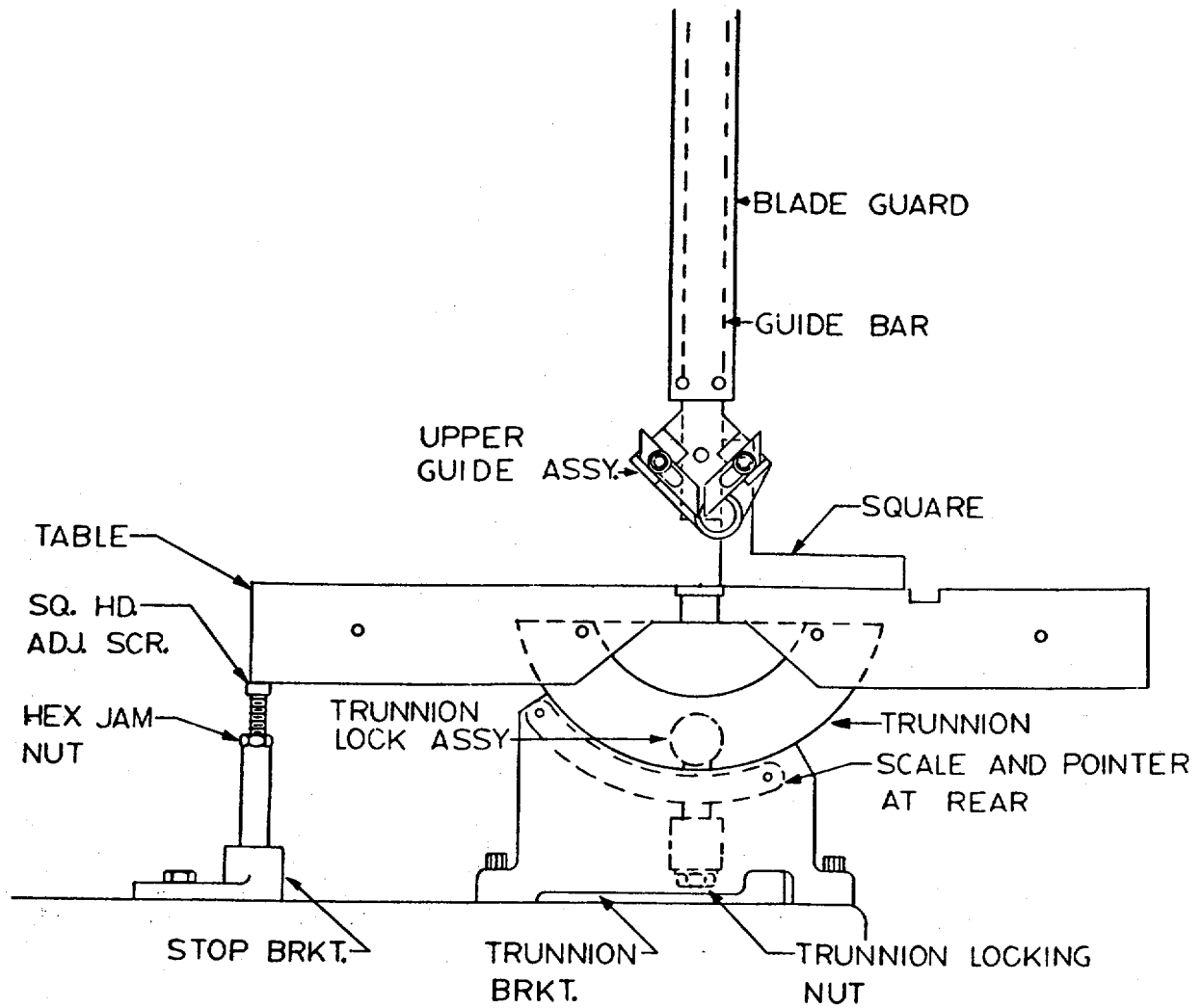

Figure 3. Table Stop Adjustments,

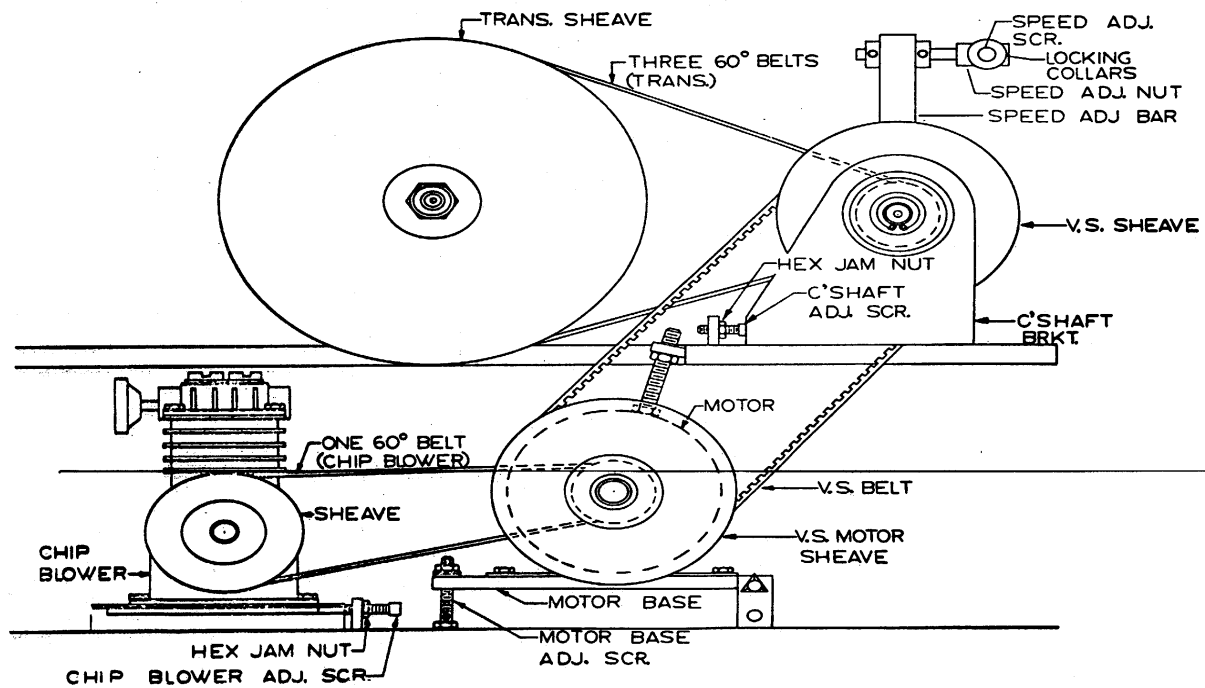

Figure 4. Drive Belt Adjustments

Figure 5 shows some of the typical operations performed on band saws.

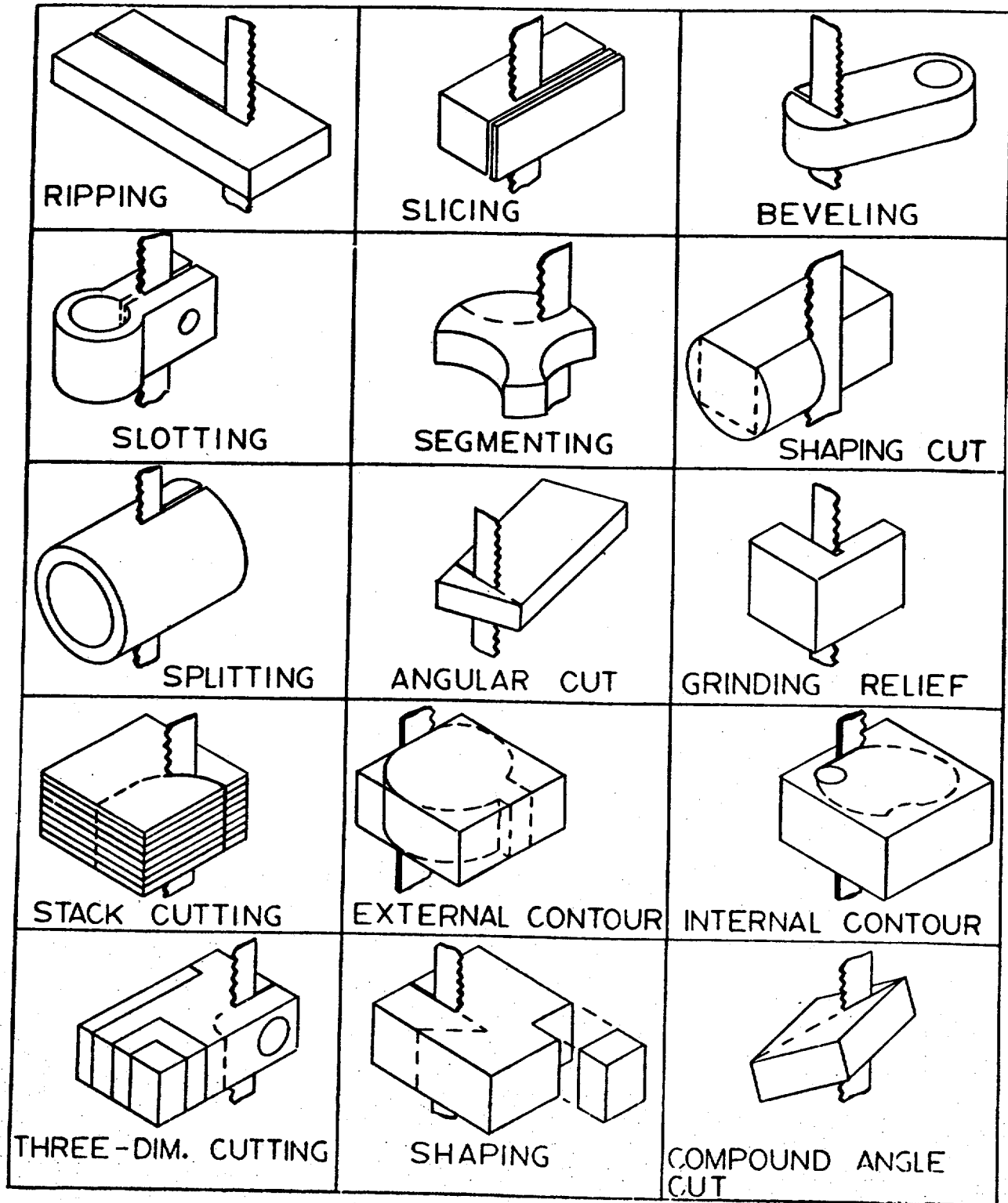

Figure 5. Typical Operations.

GENERAL SAWING INSTRUCTIONS

PRODUCTION APPLICATION CHECK LIST

- | | | | |
|---|---|-----|----------------------------|
| 1 | Plan sequence of cuts | 8 | Run one part and time cut. |
| 2 | Select saw blade and install saw guides | 9 | Check cutting rate. |
| 3 | Install and tension saw band | 10. | Adjust feed and set-up. |
| 4 | Select and mount tooling | 11. | Examine chip formation. |
| 5 | Set work stops | 12. | Check completed parts. |
| 6 | Set band speed | 13. | Change band when required. |
| 7 | Run through without parts | 14. | Clean out chip drawer. |

HIGH SPEED SAWING APPLICATIONS (USING CARBON SAW BLADE ONLY)

Only carbon blades should be used for high speed sawing applications. (Never run a high speed steel blade over 500 Surface Feet per Minute.) This refers to sawing of aluminum, magnesium, brass and other free machining metals, as well as wood, plastics, and composition materials at band speeds over 2000 FPM. Short, high speed sawing jobs may be performed with insert guides. Roller guides are preferred, however, and should be used for all long jobs and all production runs except those requiring maximum accuracy.

Most high speed sawing jobs can be fed very rapidly, usually manually, and as fast as the operator's dexterity permits on thin work

HIGH SPEED APPLICATIONS CHECK LIST

OPERATIONS

- 1 Check advisability of high speed sawing the material consulting speed and feed chart.
- 2 Select sequence of cuts.
3. Select saw blade (carbon blade).
- 4 Install roller saw guides.
- 5 Install-and tension saw band.
- 6 Select and mount tooling.
- 7 Set band speed.
- 8 Determine fastest practical feed method by trying both power and hand feed methods.
- 9 Set work stops if repetitive job.

FRICTION SAWING OPERATION

In friction sawing, momentary contact between the material being cut and the fast moving saw blade produces enough friction to heat the material to its softening point. As it becomes soft it is cut away by the saw teeth. This method cuts many times faster than conventional methods, and more important, cuts many materials which can be machined in no other way. (Band saw size-limitation $\frac{1}{2}$, $\frac{3}{4}$ & 1")

1. Coolant Mist

Coolant mist is NOT USED during friction sawing. Caution: If an oil based coolant has been used, it will be necessary to drain and clean the coolant system before friction sawing because-of the danger of sparks falling into the coolant.

2. Saw Blade

Worn out saw blades may be used for the occasional friction sawing job; It-may be difficult to guide, however, because of the uneven wear. For greatest economy. and accuracy, a-friction saw blade should be used. A low speed sawing operation will produce sharply curled chips, the result of a hard shearing action; whereas those chips produced by friction sawing are shorter with less curl and with pronounced cracks and wrinkles.

3. Operation

The speed should be turned to maximum. Hand feed is satisfactory for friction sawing if a wood pusher stick is used as a safety precaution. Friction sawing of thin material is so rapid that generally hand feed is used. The feed rate is usually limited only by the operator's dexterity. For straight cuts only a guide is needed. The standard angle plate can be used or a bar of steel clamped to the work table the desired distance from saw band by means of the universal clamps.

****IMPORTANT**

During friction sawing an extremely sharp burr is produced on the workpiece. Handle with care. Because friction sawing is a dry operation, the dust and fine chips may be objectionable. If much of it is to be done in a general shop area, simple screens can be erected to keep the dust away from other operations. Friction sawing is so fast that work handling may require greater time than sawing.

- • Material to be sawed should not exceed 3/16" in thickness. Most steel alloys are within the low melting point range and lend themselves to the friction sawing process. Annealing is not necessary since Rockwell hardness does not make an appreciable difference in friction sawing. The heat penetration into the side wall of the finished cut is almost negligible. If the cut is made too slowly, however, greater penetration will result. The most striking applications of friction sawing will be found in the cutting of stainless steels and armor plate which sometimes cannot be cut by any other method. Materials such as glass, plastics, brass and bronze, magnesium and aluminum do not lend themselves to friction sawing.

FRICTION SAWING CHECK LIST

OPERATIONS

1. Check advisability of friction sawing the material.
2. Select saw blade.,
3. Install roller guides.
4. Install and tension saw band.
5. Select and mount tooling, if any.
6. Set band speed (5200 FPM).
7. Do not use coolant. Determine fastest practical feed methods.

FOR BEST RESULTS

1. Alter speed for best cutting rate and least high speed vibration.
- 2: Wear safety glasses and gloves. Set up screen to keep chips and dirt in area.
3. Keep work surface of machine clean.
4. Arrange work handling for efficient production.

BAND SAW BLADES

Four basic differences are involved in band saw blade design and these are the number of teeth (pitch), the tooth form, the set of the teeth and blade material.

The tooth forms are shown in figure 6. In general, the thicker the workpiece, the coarser the pitch of the blade used. Follow the recommendations shown in figure 6 or pitch selection. Set patterns used on band saw blades are shown in figure 7. The raker set is one of the two most commonly used in metal cutting. The other is the wavy set used where the cross section of the work changes such as in cutting of pipe tubing and structurals. The straight set is used for blades to cut wood and plastics. Band materials may be carbon steel, carbon steel with a high speed welded edge, carbon steel with carbide tips, carbon steel with diamond tips, and high speed steel. Caution: Never run a high speed blade over 500 SFM.

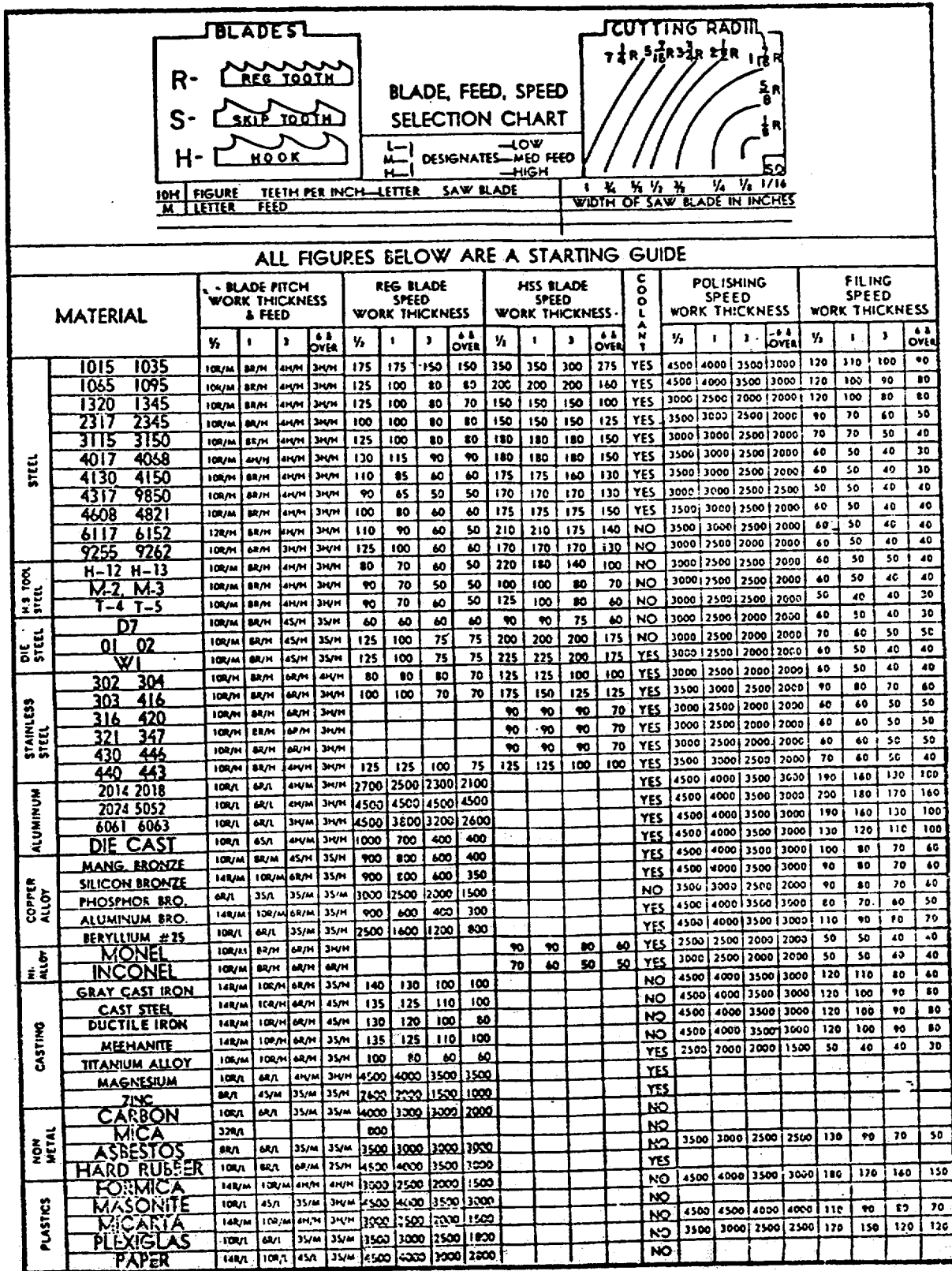

FIGURE 6.

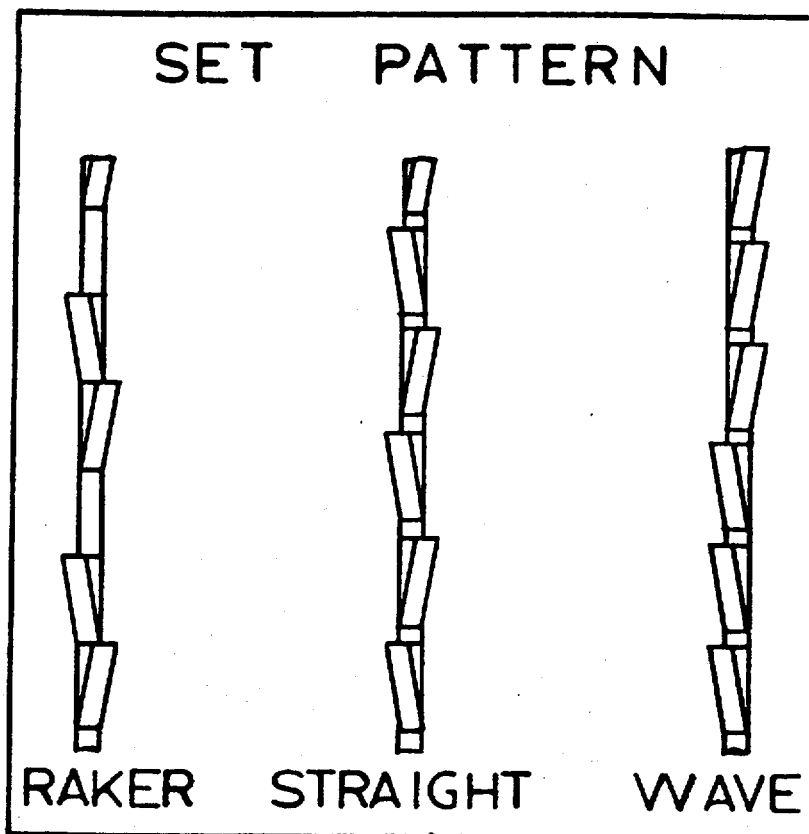

Figure 7. Saw Blade Set Patterns.

SAW OPERATIONS

The two types of sawing operations that can be performed on band saw are straight and contour cuts.

Manual feed or optional power feed is used for straight cuts. Contour cuts are made manually as when using a circle cutting attachment.

FOR ALL STRAIGHT SAWING OPERATIONS

1. Using the speed and feed chart (fig.6) or a good band sawing reference, select the speed, feed rate, blade (with reference to the radius chart when applicable), and coolant recommendations for the material and the thickness to be cut.
2. Install the blade and adjust the tension using the tension scale. Check to see if the blade is centered on the wheels against the back-up bearing of the lower guide and 1/32" or less of contacting the upper guide back-up bearing. Tilt the upper wheel as required to give these conditions. If these conditions are not met, see the band saw alignment section of the Maintenance Manual for readjustment.
3. Change or install the inserts for the blade width to be used. Slide the right hand lower guide insert to lightly contact the blade and lock in place. Bring the lower guide left hand insert to be against the side of the blade tight enough to give a slight drag if the band is pulled out by hand and then lock it in position. Align the upper guide inserts in the same fashion. If the blade to be used is less than 1/2" width, a 3/16" spacer block is used behind upper guide and the lower guide support should have the step in it facing towards the trunnion. The opposite is true for blades 1/2" wide and wider.
4. Install the fence (optional) or other work holding or guiding device.
5. Unlock and angle the table if required by the operation to set it at the desired angle and relock. Caution: With the table tilted, be sure a rail or other device is used to prevent the work piece or the cut-off portion from falling to the floor and causing injury.
6. Momentarily start and stop the machine to be sure the wheels rotate in the correct clockwise direction. If the direction is not clockwise, have the problem corrected as indicated in the maintenance section.
7. Check the position of the transmission shift lever to see if it is in the proper range for the desired speed. If not, rotate the lower wheel manually and shift into the correct range.
8. Be sure both upper and lower doors are closed. Start the machine and adjust the speed with the variable speed handwheel to set the desired surface speed. Stop the machine.
9. Place the part piece on the table.
10. Adjust the guide post to be as close to the top of the workpiece or fixture as possible and still clear to provide the maximum rigidity for the cut. Check the lower guide support; it should be in its maximum up position to bring the lower guide as close as possible to the under side of the table.
11. If air is to be used, adjust the nozzle to direct flow through the hole in the blade guard and to keep the top of the workpiece free of chips.
12. Make sure your hands are clear of the blade and start the motor. **CAUTION: Do not place the hands in line with the band saw blade.**
13. Bring the workpiece to the saw blade. If the blade is new, start with a light feed until the burrs are gone from the saw blade teeth. Feeding should be at a rate which is comfortable for the operator to maintain. Devices such as the optional rip fence or miter gauge can help in making straight cuts. An optional screw feed attachment to reduce the feeding effort and increase the rate of feed (see section on powerfeed) is an optional accessory. For narrow or thin work, use a push stick or block to avoid having to place the hands close to the blade or as in the case of thin work,

set up the possibility of slipping off the piece and making contact with the blade. Special fixtures can be used for the wide variety of special cuts that can be made on a band saw, (see page 5). Use extreme care in free-hand sawing and reduce the feed as the blade breaks out of the work to avoid losing control.

14. The saw motor should be shut off on the completion of the operations to be performed or when-ever the operator leaves the area. Keep the table free of chips by using a brush. Never clear chips with your hand.

OPTIONAL ACCESSORIES

CIRCLE CUTTING ATTACHMENT

The circle cutting attachment is used to cut circles either internally or externally of any diameter from 1-1/2" to 15" (fig. 23).

To mount the circle cutting attachment, fasten the clamp bracket to bottom of the guide bar. Assemble the radius bar, adjusting the bracket pointer holder and pointer. Prepare the workpiece for cutting by drilling a 1/8" pilot hole in center of the circle and marking the circumference of the circle. To set the desired radius, loosen screw and slide adjusting bracket along the radius bar. Additional adjustment is obtained by loosening screw and pivot point holder. Set pointer in center of workpiece by loosening thumb screw, and lowering pointer into pilot hole (fig 8).

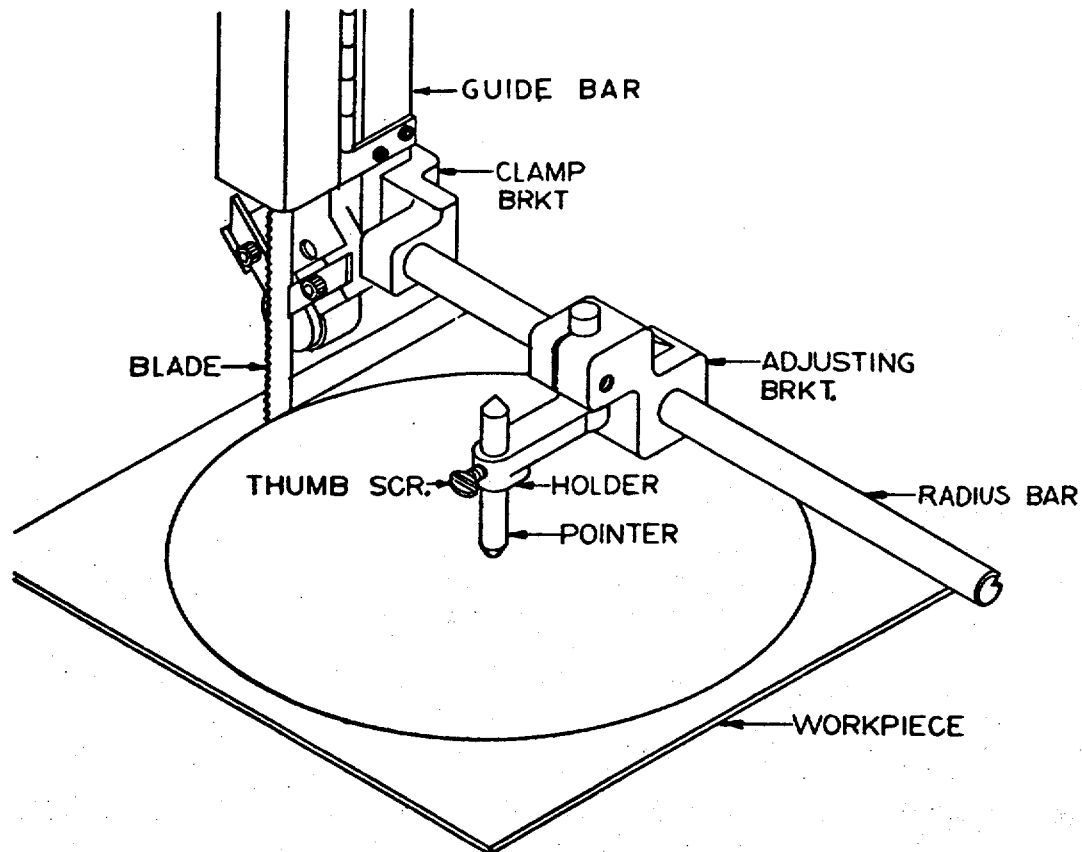

Figure 8. Mounting Circle Cutting Attachment.

OPTIONAL ACCESSORIES (continued)

2. **Miter Gauge:** The miter gauge consist.- of a bar, adjustable fence and clamp and can be used to assist in making a straight or compound angle cut-off cut. For it to be used on a Model 87 band saw, the purchaser must buy a tee-slotted table. A stop rod assembly may also be used with the miter gauge to set the distance for repetitive cut-off operations (fig. 25) .
3. **Fence:** The rip fence mounts and clamps on rails which are mounted on the front of the table. It can be used on either side of the blade to assist in guiding the stock for ripping (long straight cuts) type operations (fig. 29).
4. **Chip Blower:** This assembly consists of a compressor, the necessary piping, drive components, and nozzle to provide an air supply to blow chips from the top of the workpiece to help the operator follow a straight or contour sawing line by keeping it free of chips (fig. 28).
5. **Chute:** An exhaust chute connected to a properly sized dust³/₄, collecting system will keep dust and other blade produced debris to a minimum (fig. 35)
6. **³/₄" Capacity Blade Welder:** This accessory. allows the operator to weld carbon steel or welded edge band saw blades from 1/16" to ³/₄" wide. See the Welder Manual for operation and maintenance.
7. **Blade Shear:** A blade shear is used to square and cut off the ends of band saw blades to prepare them for welding.
8. **Band Saw Filing Attachment:** Some craftsmen prefer to file the flash from band saw blades after welding instead of grinding it off. The band saw filing attachment provides the means-for holding and supporting the blade for filing.
9. **90° Twist Bracket Kit:** This accessory provides the parts for mounting the guides at 90° from their normal position so that the blade may be twisted to be perpendicular to the guide bar and permit long workpieces such as pipe to be cut off (fig. 31)
10. **Screw Feed Attachment:** This device provides a means of increasing feed force by use of a block and screw assembly attached to the front of the table. Using the handle on the threaded screw with the screw-straight against the workpiece or work holding device, the workpiece is jackscrewed into the blade taking advantage of the force multiplying action of the screw.

OPTIONAL ACCESSORIES (continued)

11. **Work Light:** This accessory consists of a lamp and a flexible mount which allows for ease of adjustment in positioning the lamp where the operator wants it.
12. **Powerfeed:** If the band saw is equipped with an optional powerfeed unit (fig. 27), the following steps are used to set up for power sawing.
 1. Position the feed-weight by unlocking it and sliding it along the bar. The farther the weight is from the pivot point of the bar, the higher the feed force. It is better to feed a little slower than possible than to saw at maximum rate and reduce blade life.
 2. Step on the foot pedal applying enough force to latch it in position.
 3. Using material guide against the workpiece and with the workpiece against the blade, wrap the chain around the material guide and hook each end to the powerfeed cables with as little play as possible.
 4. Start the saw.
 5. Hold back on the material guide and release the latch on the foot pedal. To stop feed, step on foot pedal and re-latch it.
 6. Gradually release the material guide until all the powerfeed force is being used in the sawing action.
 7. If sawing through a part, hold back on the material guide as the saw blade breaks through to avoid jamming the blade against the material guide. Re-latch foot pedal to stop feed.

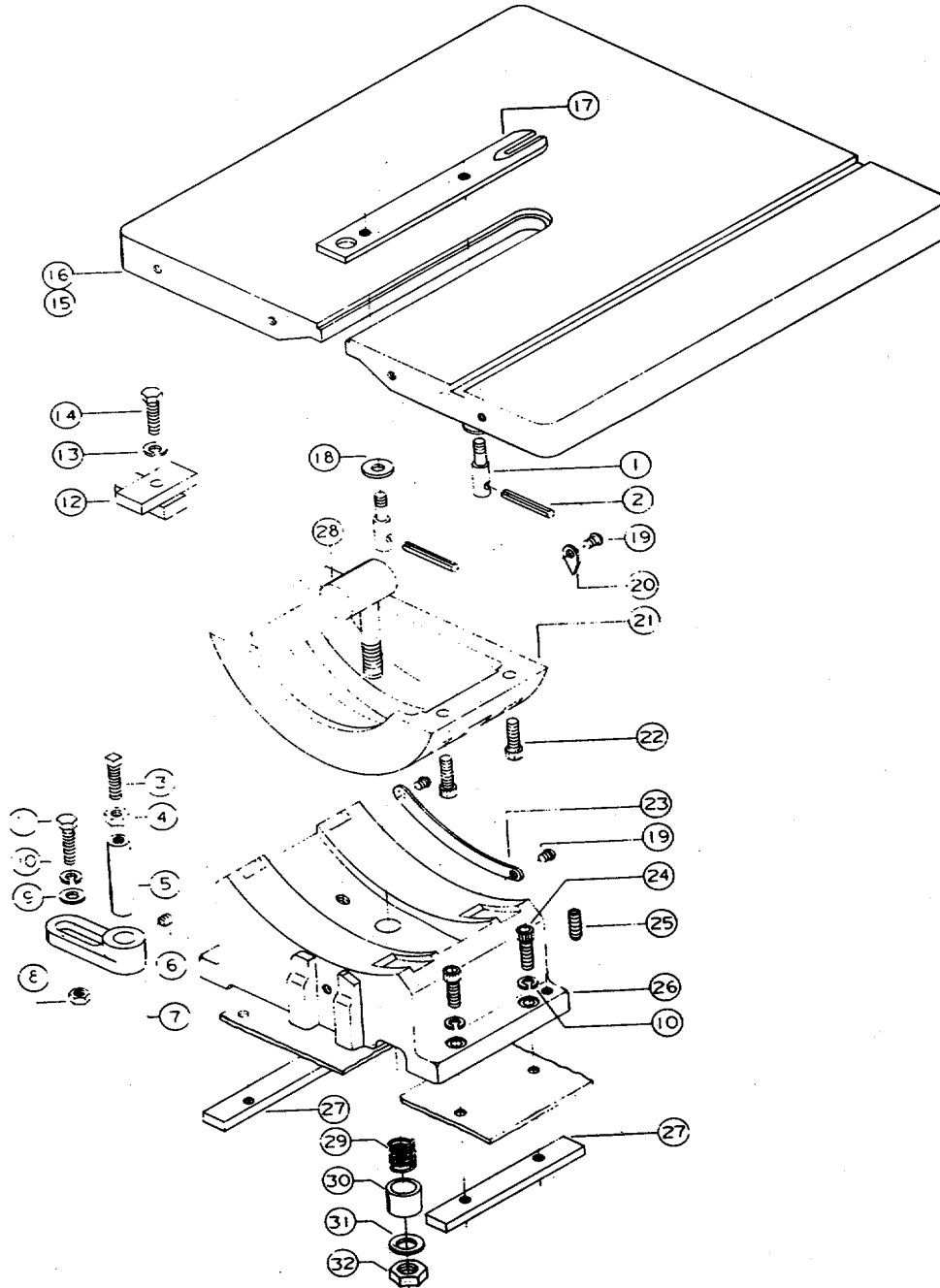

Figure 9. Table and Trunnion Assembly (Standard).

TABLE AND TRUNNION
ASSEMBLY PARTS LIST

TABLE AND TRUNNION
ASSEMBLY PARTS LIST

ITEM NO.	PART NO.	DESCRIPTION	QTY
	2695503	SCREWASSEMBLY, INSERT LOCK (ITEMS 1 & 2)	
1	3695205	SCREW, TABLE INSERT	1
2	6626033	PIN, SPRING, 3/16" DIA. X 2" Lg	1
	2761001	STOP ASSEMBLY, TABLE BRACKET (ITEMS 3 THRU 7)	
3	6716083	SCR., SQ., HD. SET, 3/8-16 x 1-3/4"	1
4	6516009	NUT, HEX JAM, 3/8-16	
1			
5	3583013	PIN, LOCATING, TABLE STOP BRACKET	1
6	6715016	SCR., SOC. SET, CUP PT., 5/16-18 x 5/16"	1
7	3274011	HANGER, COMPOUND SHEAVE	1
8	6516001	NUT, HEX, 3/8--16	1
9	6861301	WASHER, 3/8" FLAT	1
10	6861300	WASHER, 3/8" LOCK	5
11	6716039	SCR., HEX HD. CAP 3/8-16x 1-1/4"	1
12	2253025	GUIDE ASSY. TRUNNION	1
13	686T200	WASHER, 5/16" LOCK	1
14	6715044	SCR., HEX HD. CAP 5/16--18 x 2"	1
15		3797072TABLE, BAND SAW (W.O. T-SLOT)	1
16	379073	TABLE, BAND SAW1 (W. T-SLOT)	
17	3328040	INSERT, TABLE	1
18	3837035	WASHER, 3/8" I.D. x 1-3/8" O.D. x 3/16" THICK	2
19	67417000	SCR., DRIVE' No. 4 x 3/16"	3
20	3604001	POINTER	1
21	3810003	TRUNNION, TABLE TILTING	1
22	6716016	SCR., SOC. HD. CAP4 3/8--16 x 7/8"	
23	3684212	SCALE, TRUNNION TILT	1
24	6716017	SCR., SOC. HD. CAP 3/8-16 x 1-3/4"	4
25	6716100	SCR., SOC. SET, HALF DOG PT., 3/8--16 x 3/4"	2
26	3064070	BRACKET, TRUNNION, TABLE TILTING	1
27	3044322	BAR, TRUNNION BRACKET MOUNTING	2
28	2440010	LOCKASSY., TRUNNION	1
29	6813044	SPRING, COMPRESSION No. 12101	1

ITEM NO.	PART NO.	DESCRIPTION	QTY
30	3735054	SPACER, LOCKING	1
31	6861701	WASHER, 5/8" FLAT	1
32	6520011	NUT, HEX, 5/8-11 (Heavy)	1)
33	3722019	SHIM, LAMINATED TRUNNION (NOT SHOWN)	
34	3722020	SHIM, TRUNNION (NOT AS REQ SHOWN)	

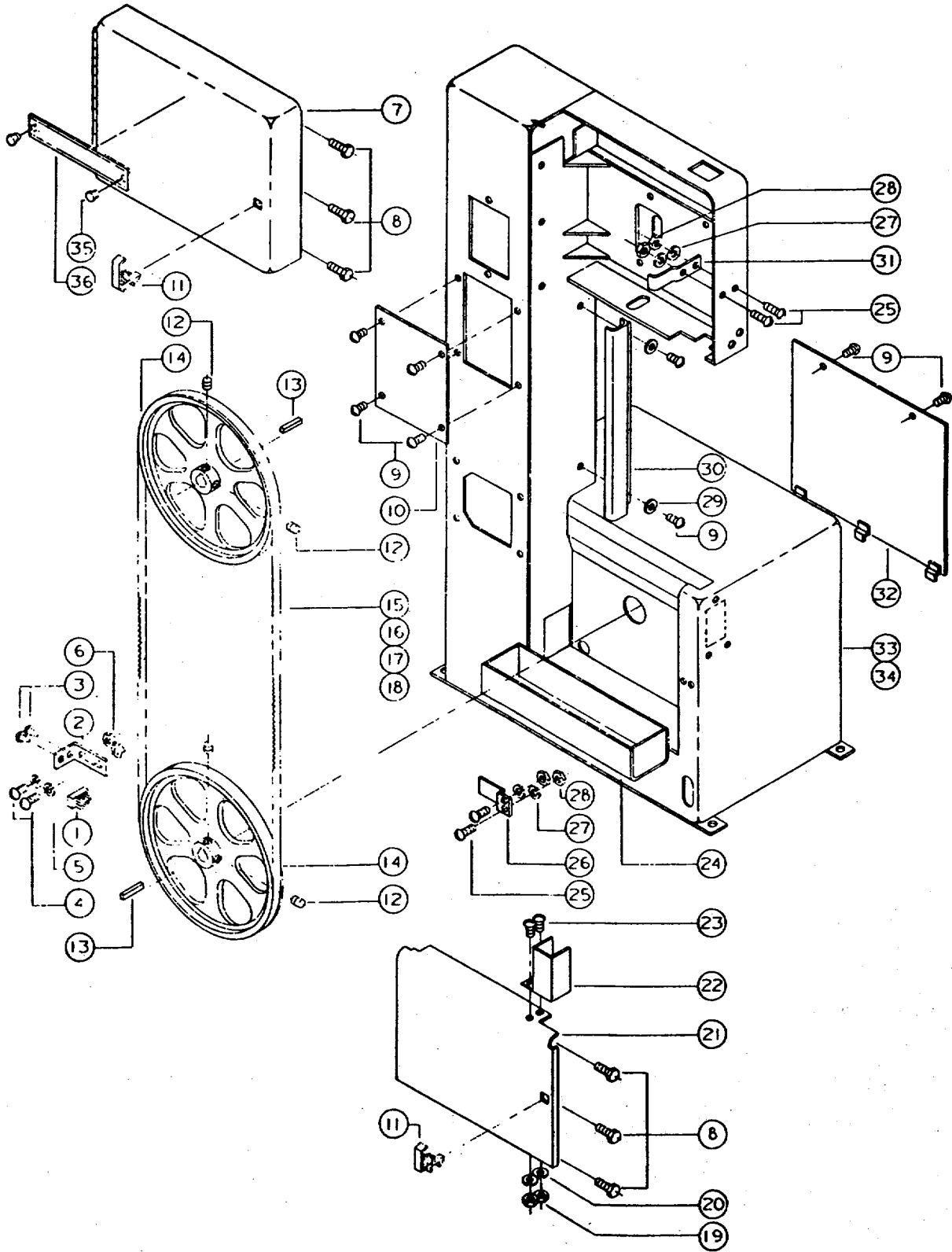

Figure 10. Body Assembly (Standard).

BODY ASSEMBLY PARTS LIST

ITEM NO.	PART NO.	DESCRIPTION	QTY
	2072001	BRUSH ASSY., LOWER WHEEL (ITEMS 1 THRU 3)	
1	3072002	BRUSH, WHEEL CLEANING	1
2	3064005	BRACKET, MOUNTING	1
3	6748002	SCR., RD. HD. WOOD No. 6 x 1/2", BLUED	2
4	6086014	BOLT, CARRIAGE, 1/4-20 x 3/4"	2
5	6861100	WASHER, 1/4" LOCK	2
6	6514001	NUT, HEX, 1/4-20	2
7	2136028	DOOR ASSY., UPPER (WELDMENT)	1
8	6715007	SCR., HEX WASHER HD. TAPTITE, 5/16-18 x 1/2"	6
9	6714114	SCR., RD HD. MACH., 1/4-20 x 3/8"	8
10	3104035	COVER, WELDER CUTOUT	1
11	6440005	LATCH, DOOR (UPPER & LOWER)	2
12	6716003	SCR., SOC., SET, CUP PT., 3/8-16 x 3/8"	4
13	3388020	KEY, 1/4 x 1.4 x 2"	2
14	2850003	WHEEL ASSY., UPPER & LOWER	2
15	6080021	BLADE, METAL CUTTING 3/8 x 151 x 14p (STD.)	1
16	6080020	BLADE, METAL CUTTING 1/4 x 151 x 14P (OPT.)	1
17	6080022	BLADE, METAL CUTTING 1/2 x 151 x 14P (OPT.)	1
18	6080103	BLADE, METAL CUTTING 3/4 x 151 x w/6P (OPT.)	1
19	6506001	NUT, HEX, No. 6-32	2
20	6860602	WASHER, No. 6 LOCK	2
21	2136029	DOOR ASSY., LOWER (WELDMENT)	1
22	3250287	GUARD, LOWER DOOR	1
23	6706038	SCR., RD. HD. MACH., No. 6-32 x 1/2"	2
24	2577001	DUST PAN ASSY (WELDMENT)	1
25	6710034	SCR., RD. HD. MACH. No. 10-24 x 1/2"	4

BODY ASSEMBLY PARTS LIST

ITEM NO.	PART NO.	DESCRIPTION	QTY
26	3420008	LATCHBLOCK, LOWER	1
27	6860802	WASHER, No. 10 LOCK	4
28	6510001	NUT, HEX, No. 10-24	4
29	6861101	WASHER, 1/4" FLAT	2
30	3250222	GUARD, BLADE COLUMN	1
31	3420009	LATCHBLOCK, UPPER	1
32	2136033	DOOR ASSY., MOTOR DR.)	1
33	2056020	BODY ASSY., 20" STD. MACHINE	1
34	2056025	BODY ASSY., BAND SAW 24" UNDER GUIDES	1
	2388056	KIT, PLAT, I.D. SPEED DECAL, ETC., (ITEMS 35 THRU 45)	2
35	6680020	RIVET, ALUM., 5/32 x 1/4"	1
36	3312254	PLATE, I.D.	1
36	3312228	PLATE, I.D. SERIAL NO. (NOT SHOWN)	.0
38	6747001	SCR., DRIVE, No. 4 x 1/4" (NICKEL PLATED) (NOT SHOWN)	1
39	3330254	PLATE, INSTRUCTION SAW OPERATING	1
40	3330276	PLATE, INSTRUCTION BLADE LENGTH (NOT SHOWN)	1
41	3085203	CHART, BLADE SPEED & FEED SELECTING (NOT SHOWN)	1
42	3330233	PLATE, INSTRUCTION, CHANGE OF SPEEDS (NOT SHOWN)	1
43	3330283	PLATE, SAFETY (NOT SHOWN)	1
44	3684259	SCALE, SPEED (NOT SHOWN)	1
45	3330300	PLATE, SHIFT INSTRUCTION (NOT SHOWN)	

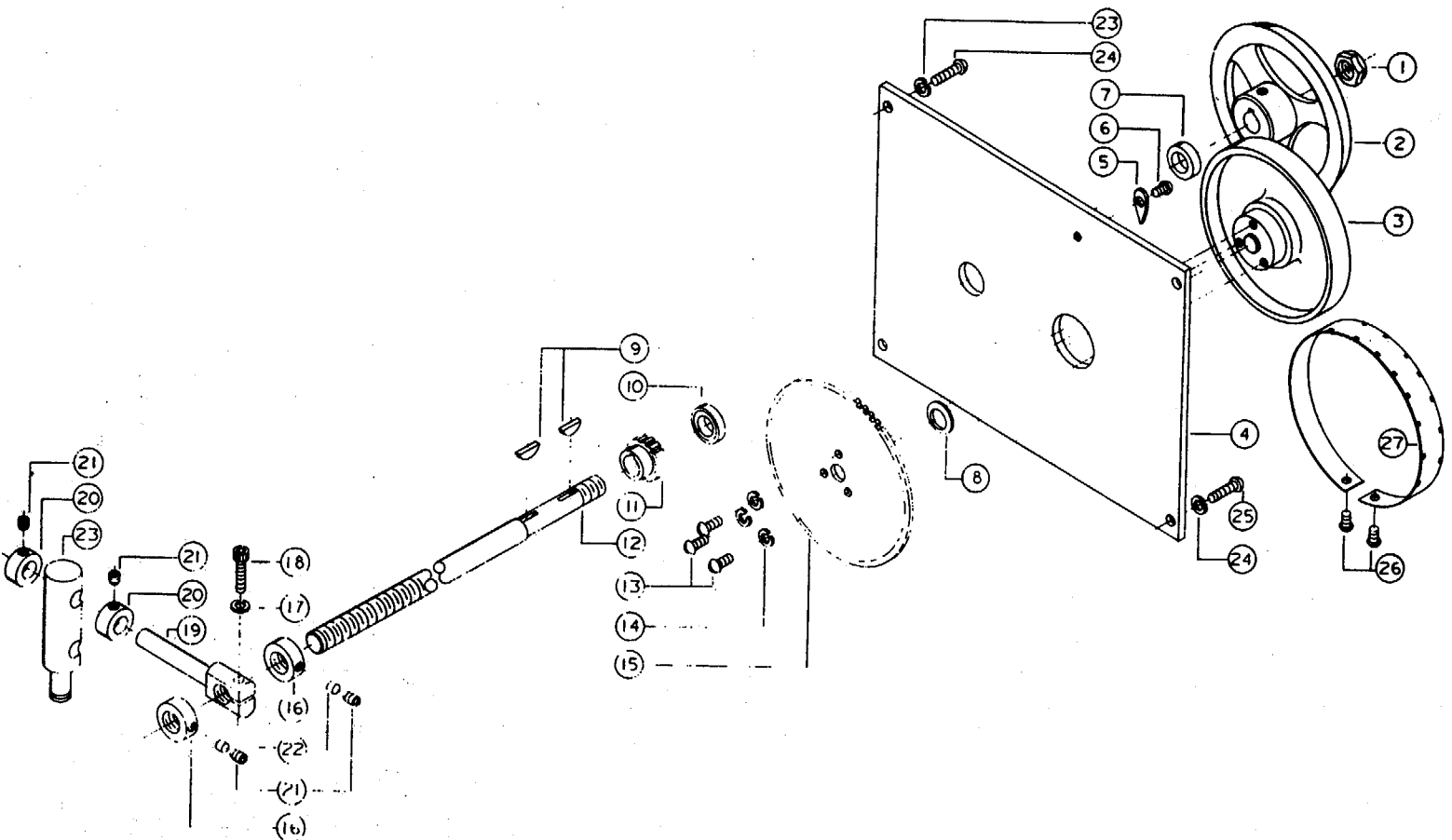

Figure 11. Speed Adjusting Control Assembly (Standard).

**SPEED ADJUSTING CONTROL
ASSEMBLY PARTS LIST**

ITEM NO.	PART NO.	DESCRIPTION	QTY
	2089006	CONTROL ASSEMBLY, SPEED ADJ. (ITEMS 1 THRU 22)	
1	6568010	NUT, 1/4-20 (THIN HT.)	1
2	3271049	HANDWHEEL, 6" DIA.	1
3	3148007	DRUM, SPEED DIAL	1
4	3595334	PLATE, SPEED ADJUSTMENT MOUNTING	1
5	3604001	POINTER	1
6	6705010	SCR., ROUND HD., MACH., No. 5-40 x 3/8"	1
7	6095175	BUSHING, BRONZE .503/.502 I.D. x .628/.627 O.D. x 1/4"	1
8	6861508	WASHER	1
9	6420000	KEY,	2
10	6064000	BEARING	1
11	3237336	GEAR, SPEED DIAL	1
12	3701051	SHAFT, SPEED ADJUST.	1
13	6710033	SCR., ROUND HD. MACH. No. 10-24 x 3/8"	3
14	6860802	WASHER, No. 10 LOCK	3
15	3237314	GEAR, SPEED DIAL	1
16	3096099	COLLAR	2
17	6861100	WASHER, 1/4" LOCK	1
18	6714016	SCR., SOC. HD. CAP, 1/4-20 x 1"	1
19	3526083	NUT, SPEED ADJUSTMENT	1
20	3096061	COLLAR, PINION SHAFT	2
21	6714004	SCR., SOC. SET, CUP PT. 1/4- 20 x 1/4"	4
22	3598028	PLUG	2
23	3044308	BAR, SPEED ADJUSTMENT	1
24	6861100	WASHER, 1/4" LOCK	4
25	6714063	SCR., ROUND HD. MACH., 1/4-20 x 1/2"	4
26	6747001	SCR., DRIVE, No. 4 x 4-1/4 (NICKEL PLATED)	2
27	3684259	SCALE, SPEED	1

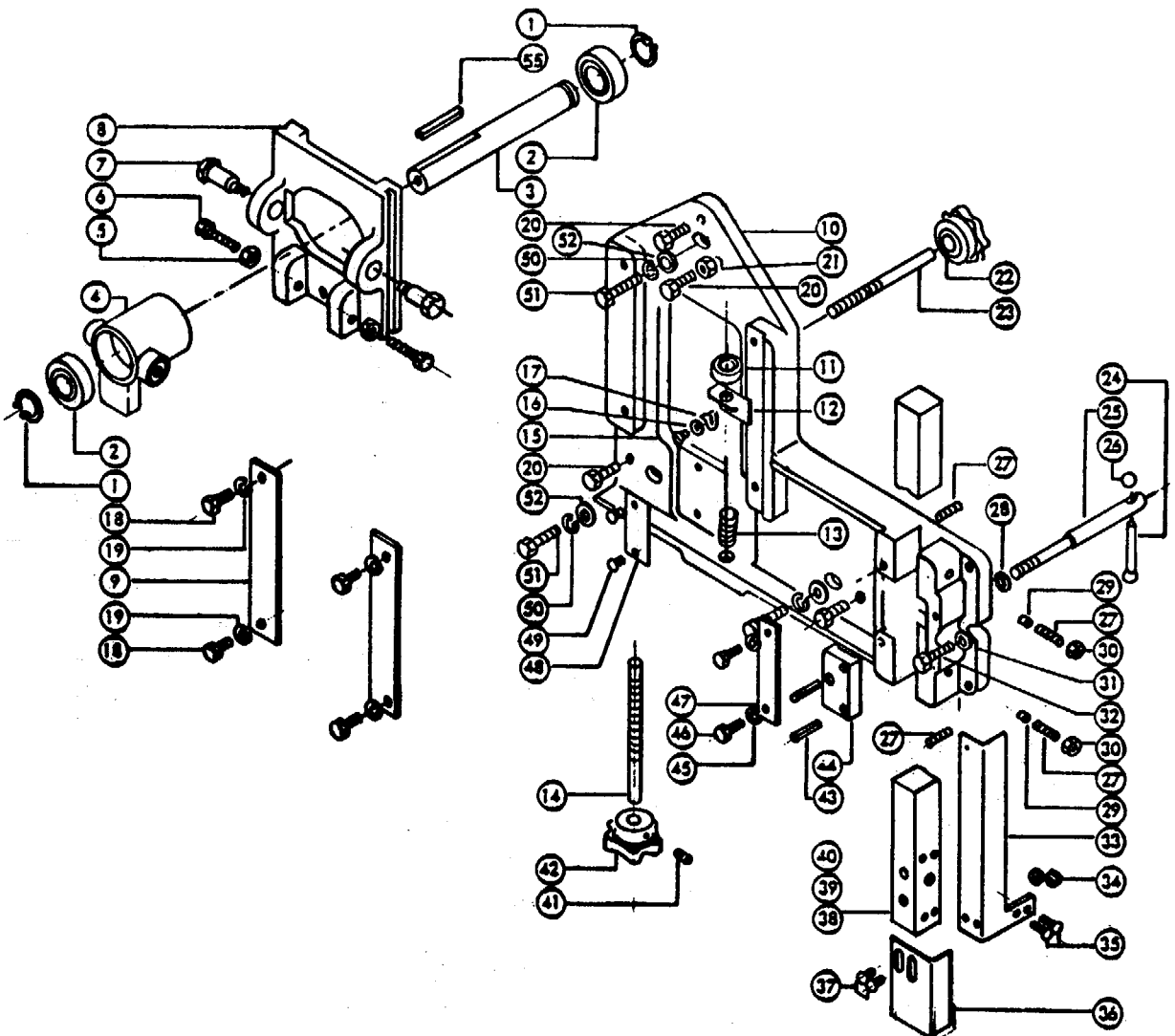

Figure 12. Upper Wheel Housing Assembly (Standard).

**UPPER WHEEL HOUSING
ASSEMBLY PARTS LIST**

**UPPER WHEEL HOUSING
ASSEMBLY PARTS LIST**

ITEM NO.	PART NO.	DESCRIPTION	QTY
	2730021	SLIDE ASSEMBLY (ITEMS 1 THRU 21)	
	2298029	HOUSING ASSY., UPPER SHAFT BRG. (ITEMS 1 THRU 4)	
1	6670096	RING, RETAINING,	2
2	6060014	BEARING, BALL, SKF No. 6206-2Rs	2
3	3700014	SHAFT, UPPER WHEEL	1
4	3298034	HOUSING, UPPER SHAFT BEARING	1
5	6516009	NUT, HEX JAM, 3/8-16	2
6	6716032	SCR., HEX HD., 3/8-16 x 1-1/2"	2
7	3058011	BOLT, UPPER WHEEL PIVOT	2
8	3063041	BRACKET, UPPER BEARING HOUSING MOUNTING	1
9	3244035	GIV, UPPER BEARING HOUSING SLEEVE	2
10	3064289	BRACKET, UPPER WHEEL HOUSING	1
11	6064000	BEARING, THRUST,	1
12	3094011	CLIP, SPRING	1
13	6813061	SPRING,	1
14	3690029	SCREW, TENSION ADJ.	1
15	6706037	SCR., ROUND HD., 6-32 x 31/6"	1
16	6860600	WASHER, FLAT NO. 6	1
17	3604004	POINTER	1
18	6716030	SCR., HEX HD., 3/8-16 x 3/4"	4
19	6861300	WASHER, 3/8" LOCK	4
20	6718010	SCR., HEX HD., CAP 1/2-13 x 1-1/2"	4
21	6518008	NUT, HEX, 1/2-13	1
	2690001	SCREW ASSEMBLY, TILT ADJUST. (ITEMS 22 THRU 23)	
22	3406018	KNOB	
23	3690028	SCREW, TILT ADJ.	1
	2695028	SCREW ASSEMBLY, GUIDE BAR LOCK (ITEMS 24 THRU 26)	
24	3268002	HANDLE	1
25	3692036	SCREW, GUIDE BAR LOCK	1
26	3406016	KNOB, HANDLE	1
27	6716093	SCR., SOC. SET, HALF DOG Pt., 3/8-16 x 1"	4
28	6861201	WASHER, 5/16" FLAT	1

ITEM NO.	PART NO.	DESCRIPTION	QTY
29	3598022	PLUG, PROTECTOR, 5/16" Dia. x 3/16 Lg.	2
30	6516009	NUT, HEX, 3/8-16	2
31	6861301	WASHER, 3/8" FLAT	1
32	6716015	SCR., SOC. HD. CAP, 3/8-16 x 1-1/2"	1
33	2250059	GUARD ASSEMBLY, BLADE (WELDMENT)	1
34	6510005	NUT, HEX, No. 10-24	2
35	6714114	SCR., RD., HD., MACH., 1/4-20 x 3/8"	2
36	3720015	SHIELD, BLADE GUARD	1
37	6710034	SCR., RD. HD., No. 10-24 x 1/2"	2
40	3044102	BAR, GUIDE (87 B.S.)	1
41	6715013	SCR., SOC. SET, CUP PT, 5/16-18 x 3/8"	1
42	3271008	HANDWHEEL, 3-1/2"	1
43	6626029	PIN, SPRING, 3/16" DIA. x 1" LG.	2
44	3448030	LOCK, GUIDE BAR	1
45	6861100	WASHER, 1/4" LOCK	2
46	6714049	SCR., HEX HD. CAP, 1/4-20- x 3/4"	2
47	3481041	PLATE, GUIDE BAR MOUNTING	1
48	3684210	SCALE, TENSION	1
49	6747000	SCR., DRIVE, NO. 4 x 3/16"	2
50	6861300	WASHER, 3/8" LOCK	3
51	6716124	SCR., HEX HD. CAP, 3/8-16 x 2-1/4"	3
52	3838203	WASHER, BEVEL	3
53	6715092	SCR., SQ. HD. SET, 5/16-18 x 1-3/4" (HORIZ. ADJ. NOT SHOWN)	2
54	6515007	NUT, HEX JAM, 5/16-18 (HORIZ. ADJ. NOT SHOWN)	2
55	3388020	KEY, 1/4 x 1/4 x 2"	1

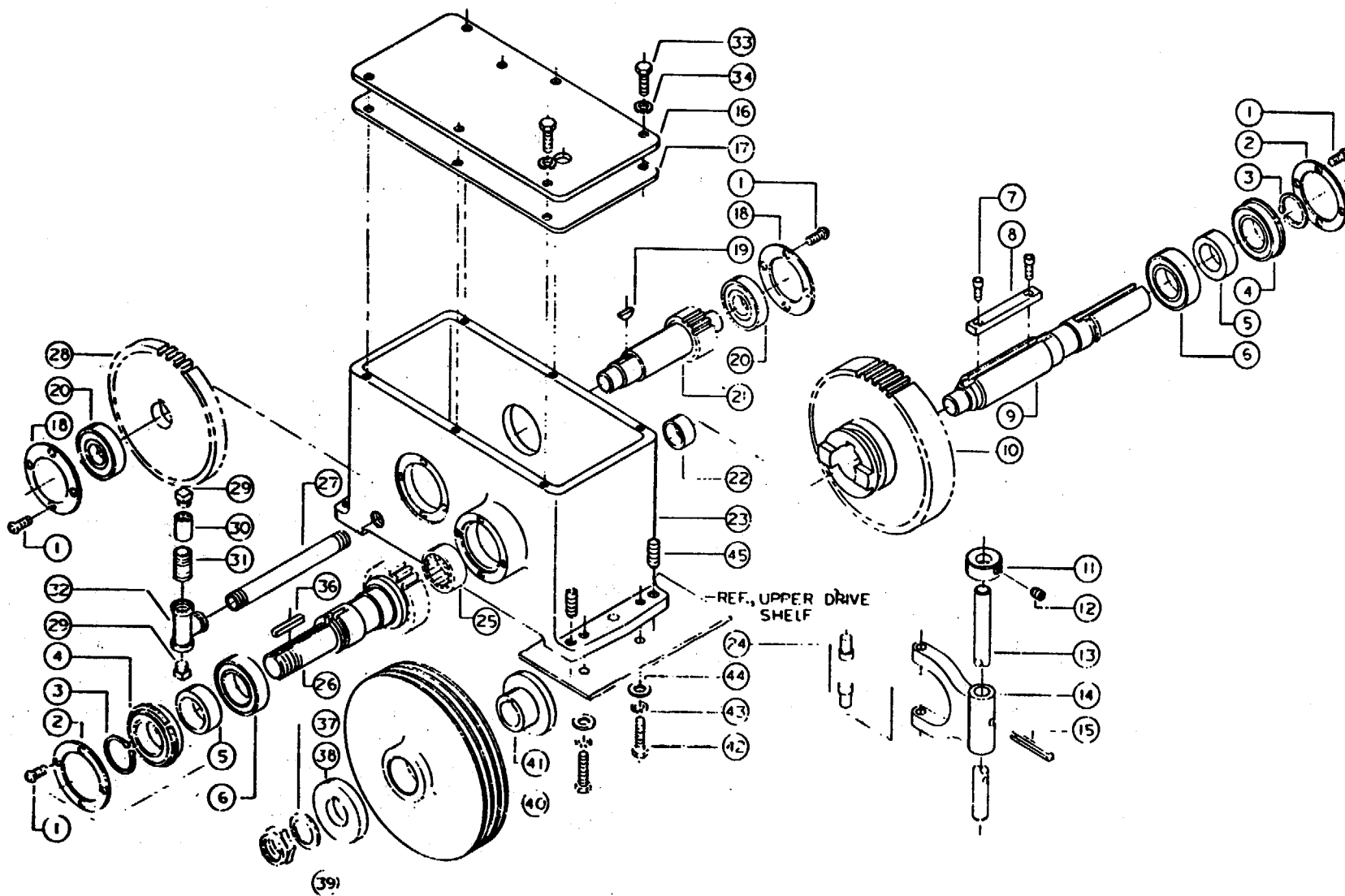

Figure 13. Transmission Assembly (Standard).

TRANSMISSION ASSEMBLY PARTS LIST

TRANSMISSION ASSEMBLY PARTS LIST

ITEM NO.	PART NO.	DESCRIPTION	QTY
		(ITEMS 1 THRU 35)	
1	2805012 6714083	TRANSMISSION ASSEMBLY SCR., SOC. HD BUTTON 1/4- 20 x 1/2"	16
2	3659016	RETAINER, BEARING	2
3	6670013	RING, RETAINING No. 5100- 137	2
4	6060184	BEARING, BALL,	2
5	3735077	SPACER, BEARING	2
6	6060185	BEARING, BALL,	2
7	6710015	SCR., SOC. HD. CAP No. 10- 24 x 1/2"	2
8	3388063	KEY, DRIVE	1
9	3700098	SHAFT, OUTPUT	1
10	3237335	GEAR, LOW SPEED DRIVEN	1
11	3096243	COLLAR	1
12	6715015	SCR., SOC, SET, CUP PT., 5/16-18 x 1/4"	1
13	3700097	SHAFT, SHIFTING	1
14	3936011	YOKE, SHIFTING	1
15	6626040	PIN, SPRING, 1/4 DIA. x 1-1/4" LG.	1
16	3800034	TOP, TRANSMISSION	1
17	3234022	GASKET, TRANSMISSION	1
18	3708078	CAP, BEARING	2
19	6420009	KEY,	1
20	6060014	BEARING, BALL,	2
21	3705016	SHAFT, COUNTER	1
22	6063013	BEARING, INNER RACE	1
23	3298367	HOUSING, TRANSMISSION	1
24	3582090	PIN, SHIFTING	2
25	6063041	BEARING, ROLLER	1
26	3700099	SHAFT, INPUT	1
27	3509005	NIPPLE, PIPE, 1/2 NPT x 9"L	1
28	3237312	GEAR, INPUT DRIVEN	1
29	6638004	FITTING, PIPE, 1/2 NPT, PLUG	2
30	6634047	FITTING, PIPE, 1/2 NPT COUPLING	1
31	6634060	FITTING, PIPE, 1/2 NPT ALL THREAD CLOSE NIPPLE	1
32	6634072	FITTING, PIPE, 1/2 NPT "T" (STRAIGHT)	1
33	6714127	SCR., HEX HD. CAP, 1/4-20 x 1/2"	6
34	6861100	WASHER, 1/4" LOCK	6
35	6605018	OIL, TRANSMISSION	3qts.

ITEM NO.	PART NO.	DESCRIPTION	QTY
36	3388066	KEY, FRICTION HUB	1
37	6863002	WASHER, BELLVILLE SPR.	1
38	3595333	PLATE, FRICTION	1
39	6576004	NUT, FLEXLOC, 1-14 (THIN HT.)	1
40	3719068	SHEAVE, TRANSMISSION	1
41	3301040	HUB, FRICTION	1
42	6716037	SCR., HEX HD. CAP, 3/8-16 x 2"	4
43	6861300	WASHER, 3/8" LOCK	4
44	3837035	WASHER, FLAT STEEL 3/8 I.D. x 1-3/8 O.D. x 3/16" THICK	4
45	6718056	SCR., SOC. SET, 1/2-13 x 3/4"	4

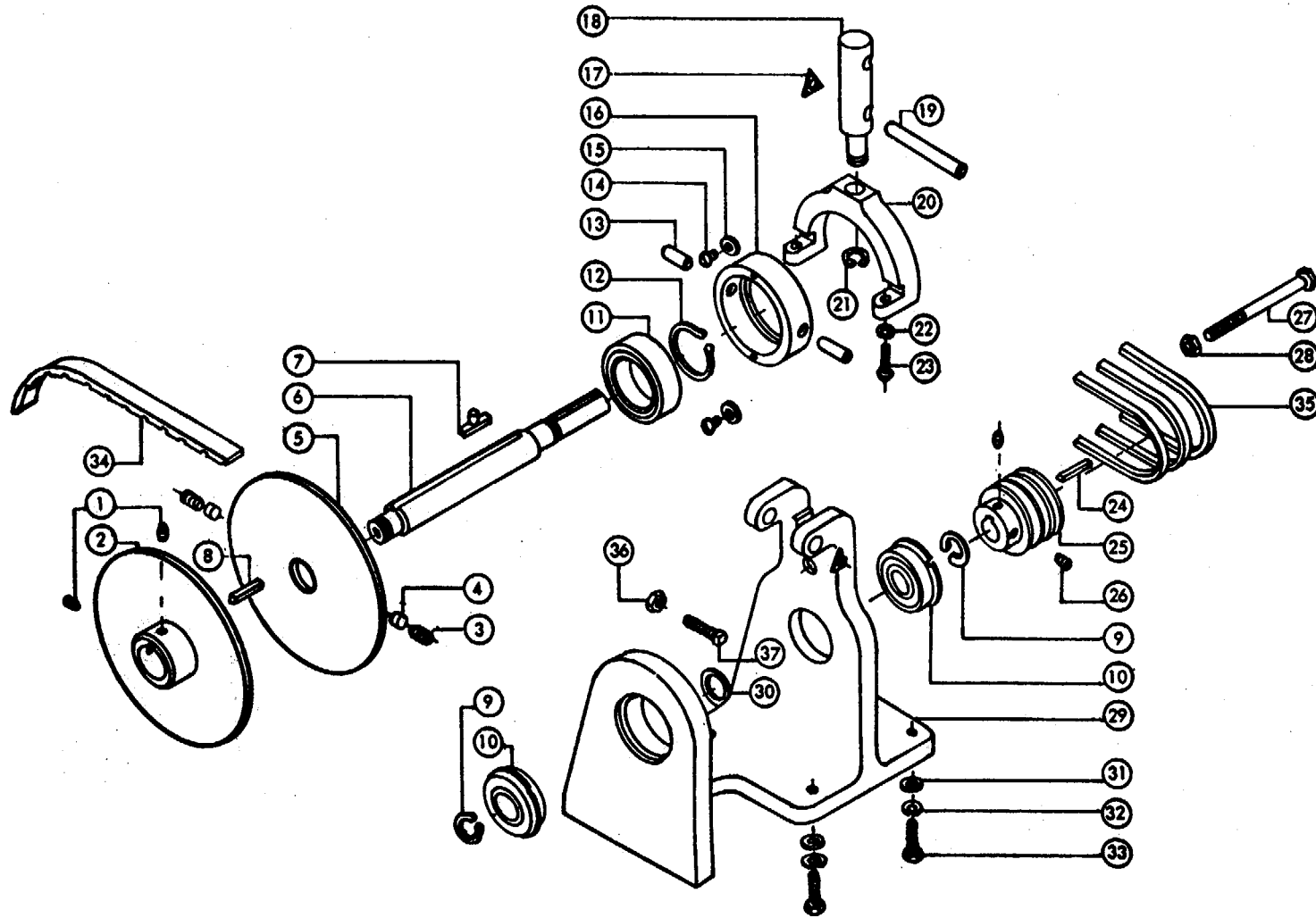

Figure 14. Countershaft Assembly (Standard).

COUNTERSHAFT ASSEMBLY PARTS LIST

ITEM NO.	PART NO.	DESCRIPTION	QTY
	2705020	COUNTERSHAFT ASSY. (ITEMS 1 THRU 30)	
	2718004	SHEAVE ASSEMBLY CTRSFT., (ITEMS 1 THRU 8)	
1	6714008	SCR., SOC. SET, KNURLED CUP PT., 1/4-20 x 5/16"	2
2	6719181	SHEAVE, V.S., FIXED	1
3	6720037	SCR., SOC. SET, KNURLED CUP PT., 5/8" - 11 x 3/4"	2
4	3598047	PLUG, BRASS	2
5	2719070	SHEAVE ASSY., V.S. SLIDING	1
6	3705019	SHAFT, COUNTER	1
7	3388069	KEY, TIT	1
8	3388068	KEY, C.F. STEEL, 3/16" x 1/4" x 1-3/16"	1
9	6670014	RING, RETAINING	2
10	6060053	BEARING, BALL	2
11	6060098	BEARING, BALL	1
12	6070125	RING, RETAINING,	1
13	6623013	PIN, DOWEL, 5/16" x 1"	2
14	6710032	SCR., ROUND HD., MACHINE, No. 10-24 x 1/4"	2
15	6860800	WASHER, No. 10, FLAT	2
16	3096098	COLLAR, BEARING	1
17	6670078	RING, RETAINING, No. 5305-37	2
18	3044308	BAR, SPEED ADJUST.	1
19	3582091	PIN, PIVOT	1
20	3936012	YOKE, SPEED ADJUST.	1
21	6670008	RING, RETAINING	1
22	6860802	WASHER, No. 10 LOCK	2
23	6710125	SCR, ROUND HD., No. 10-24 x 1-1/8"	2
24	3388009	KEY, 3/16" SQ., x 1-3/4"	1
25	3717062	SHEAVE, COUNTERSHAFT	1
26	6714003	SCR., SOC., SET, CUP PT., 1/4-20 x 3/8"	2
27	6718089	SCR., HEX HD. CAP, 1/2-13 x 7" ADJUSTING	1
28	6518001	NUT, HEX, 1/2-13	1
29	3063415	BRACKET, COUNTERSHAFT	1
30	3735082	SPACER	1
31	6861301	WASHER, 3/8" FLAT	4
32	6861300	WASHER, 3/8" LOCK	4

COUNTERSHAFT ASSEMBLY PARTS LIST

ITEM NO.	PART NO.	DESCRIPTION	QTY
33	6716031	SCR., HEX HD., 3/8-16 x 1	4
34	6077143	BELT, V.S. 1922V426	1
35	6077141	BELT, "V" 7M1180 (MATCHED SET OF 3)	1
36	6515007	NUT, HEX JAM, 5/16-18	1
37	6715092	SCR., SQ. HD. SET, 5/16-18 x 1-3/4"	1

NOTE:
 GUIDE POSITION SHOWN FOR
 BLADES UP TO $\frac{1}{2}$ " FOR $\frac{3}{4}$ "
 BLADE, REMOVE NO. ① FROM
 ASSY NO. 2253071 AND RE-
 VERSE NO. ③ FROM ASSY.
 NO. 2253068.

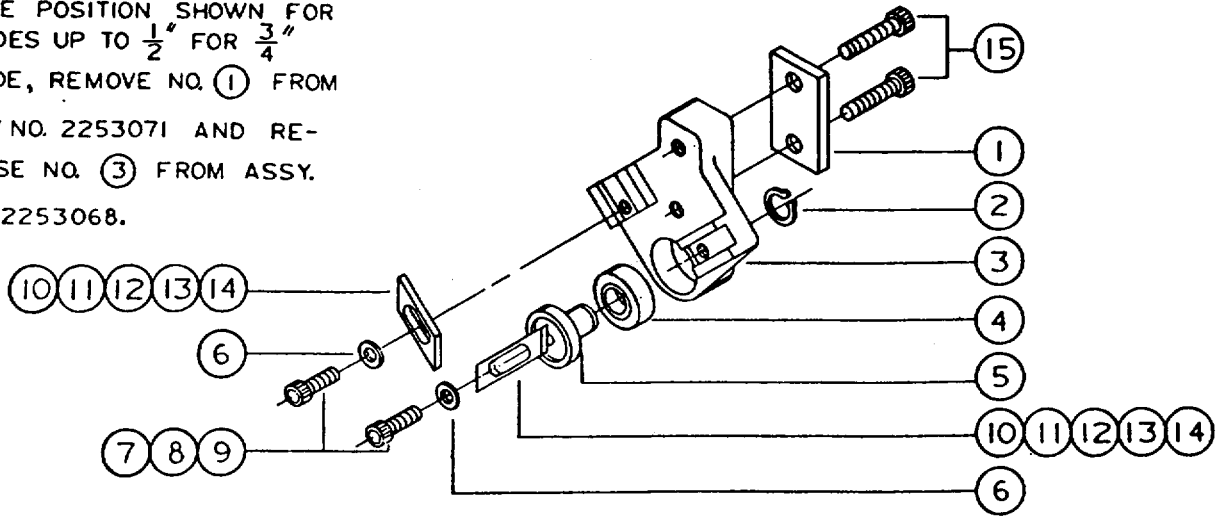

UPPER GUIDE ASSY

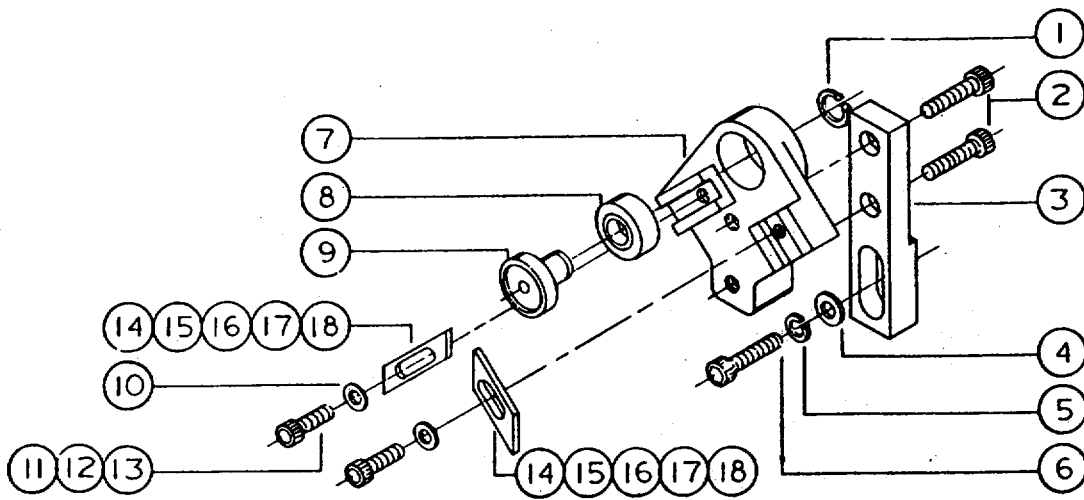

LOWER GUIDE ASSY.

Figure 15. Upper and Lower Guide Assemblies (Standard).

UPPER & LOWER GUIDE ASSEMBLY PARTS LIST

ITEM NO.	PART NO.	DESCRIPTION	QTY
	2253071	Guide Assy., 45° Upper (Items 1 thru 15)	
1	3735049	Spacer, Guide Bar	1
2	6670016	Ring, Retaining,	1
3	3253040	Guide, 45°	1
4	6061017	Bearing, Ball,	1
S	3700045	Shaft, Blade Guide Backup	1
6	6813095	Spring, .255 I.D. x .500 O.D.	2
7	6714015	Scr., Soc. Hd. Cap, 1/4-20 x 1/2" (W/Inserts 3328216 & 7	2
8	6714016	Scr., Soc. Hd. Cap, 1/4-20 x 1 (W/Insert 3328220)	2
9	6714018	Scr., Soc. Hd. Cap, 1/4-20 x 3/4" (W/Inserts 3328218 & 9)	2
10	3328216	Insert, 450, 1/8" Blade	2
11	3328217	Insert, 450, 1/4" Blade	2
12	3328218	Insert, 450, 3/8" Blade	2
13	3328219	Insert, 450, 1/2" Blade	2
14	3328220	Insert, 450, 3/4" Blade	2
15	6716013	Scr., Soc. Hd. Cap, 3/8-16 x 1-3/4"	2
	2253068	Guide Assy, 450 Lower (Items 1 thru 18)	
1	6670016	Ring, Retaining,	1
2	6716016	Scr., Soc. Hd. Cap, 3/8-16 x 7/8"	2
3	3044203	Bar, Lower Guide Mounting	1
4	6861301	Washer, 3/8" Flat	1
S	6861300	Washer, 3/8" Lock	1
6	6716013	Scr., Soc. Hd. Cap, 3/8-16 x 1-3/4"	1
7	3253040	Guide, 45°	1
8	6061017	Bearing, Ball,	1
9	3700045	Shaft, Blade Guide Backup	1
10	6813095	Spring, .225 I.D. x .500")O.D.	2
11	6714015	Scr., Soc. Hd. Cap, 1/4-20 x 1/2" (W/inserts 3328216 & 7)	2
12	6714016	Scr., Soc. Hd. Cap, 1/4-20 x 1 (W/Insert 3328220)	2
13	6714018	Scr., Soc. Hd. Cap, 1/4-20 x 3/4" (W/inserts 3328218 & 9)	2
14	3328216	Insert, 45°, 1/8" Blade	2
15	3328217	Insert, 45°, 1/4" Blade	2
16	3328218	Insert, 45°, 3/8" Blade	2
17	3328219	Insert, 45°, 1/2" Blade	2
18	3328220	Insert, 450, 3/4" Blade	2

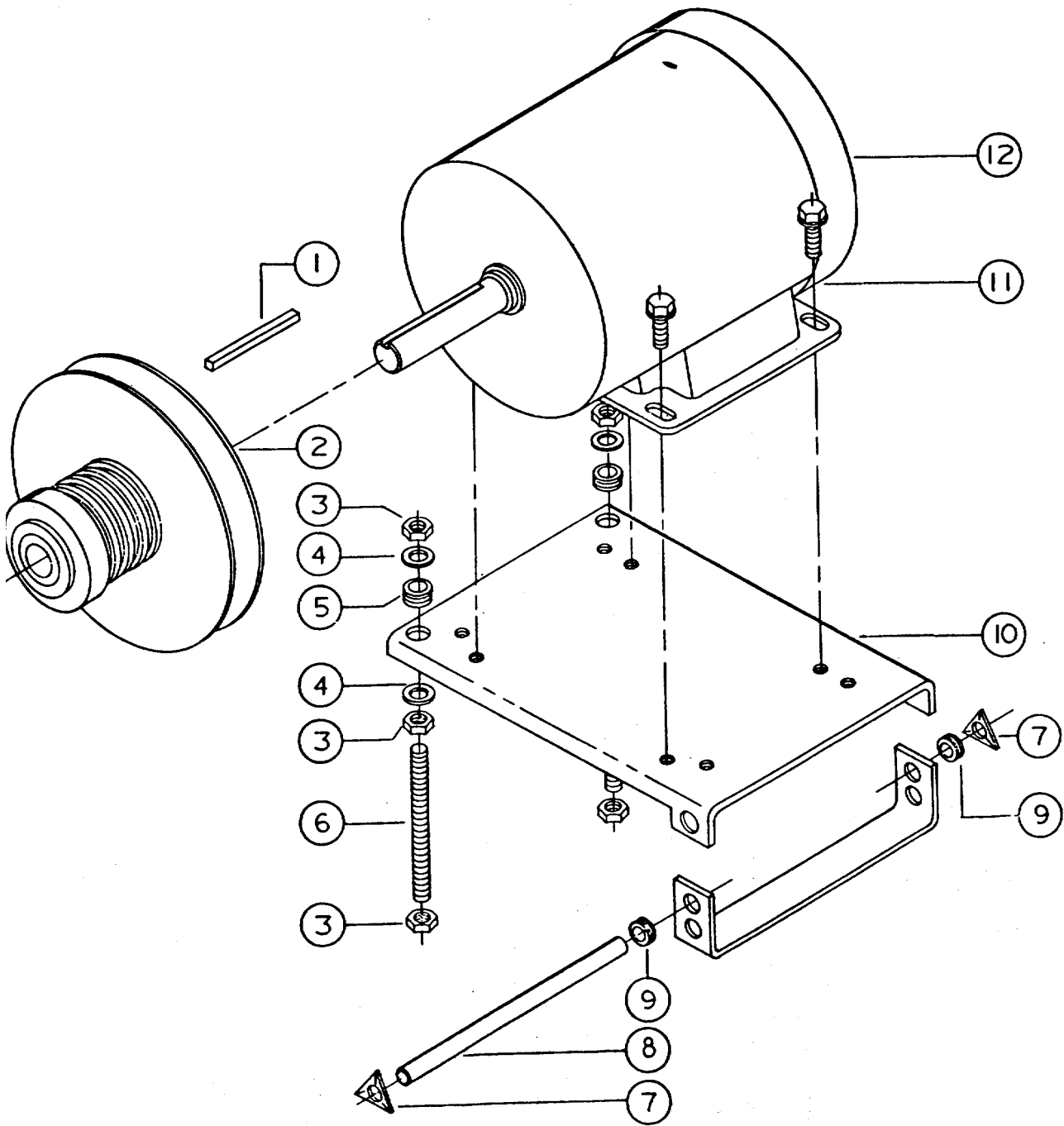

Figure 16. Motor Mounting Assembly (Standard).

MOTOR MOUNTING ASSEMBLY PARTS LIST

ITEM NO.	PART NO.	DESCRIPTION	QTY
1	3388013	Key, 3/16 x 3/16 x 2-3/4"	1
2	2719083	Sheave Assembly, V.S. Motor	1
3	6515007	Nut, Hex, 5/16-18	6
4	6861201	Washer, 5/16" Flat	4
5	6336008	Grommet, Rubber (Adjusting Stud)	2
6	3773301	Stud, Mounting Base Adjusting	2
7	6670078	Ring, Retaining No. 5305-37	2
8	3584035	Pin, Pivot	1
9	6336001	Grommet, Rubber (Pivot)	2
10	2595016	Plate Assy., Motor Mounting	1
11	6715180	Scr., Hex Washer Hd., 5/16-18 x 5/8"	4
12	6471603	Motor, 2 Hp, 3 Ph, 1800 Rpm, 60 Hz, 230/460v, 145T,	
	6471616	Motor, 2 Hp, 3 Ph, 1800 Rpm, 60 Hz, 575v, 145T,	
	6471617	Motor, 2 Hp, 3 Ph, 1800 Rpm, 60 Hz, 200v, 145T,	
	6471627	Motor, 2 Hp, 1 Ph, 1800 Rpm; 60 Hz, 115/230v, 182,	
	6471916	Motor, 3 Hp, 3 Ph, 1800 Rpm, 60 Hz, 208/220/440v, 182/184,	
	6471301	Motor, 1-1/2 Hp, 1 Ph, 1800 Rpm, 60 Hz, 115/230v, 14 ST,	
	6471304	Motor, 1-1/2 Hp, 3 Ph, 1800 Rpm, 60 Hz, 230/460v, 145T,	
	6471317	Motor, 1-1/2 Hp, 3 Ph, 1800 Rpm, 60 Hz, 145T,	
	6471322	Motor, 1-1/2 Hp, 3 Ph, 1800 Rpm, 60 Hz, 200v, 145T,	

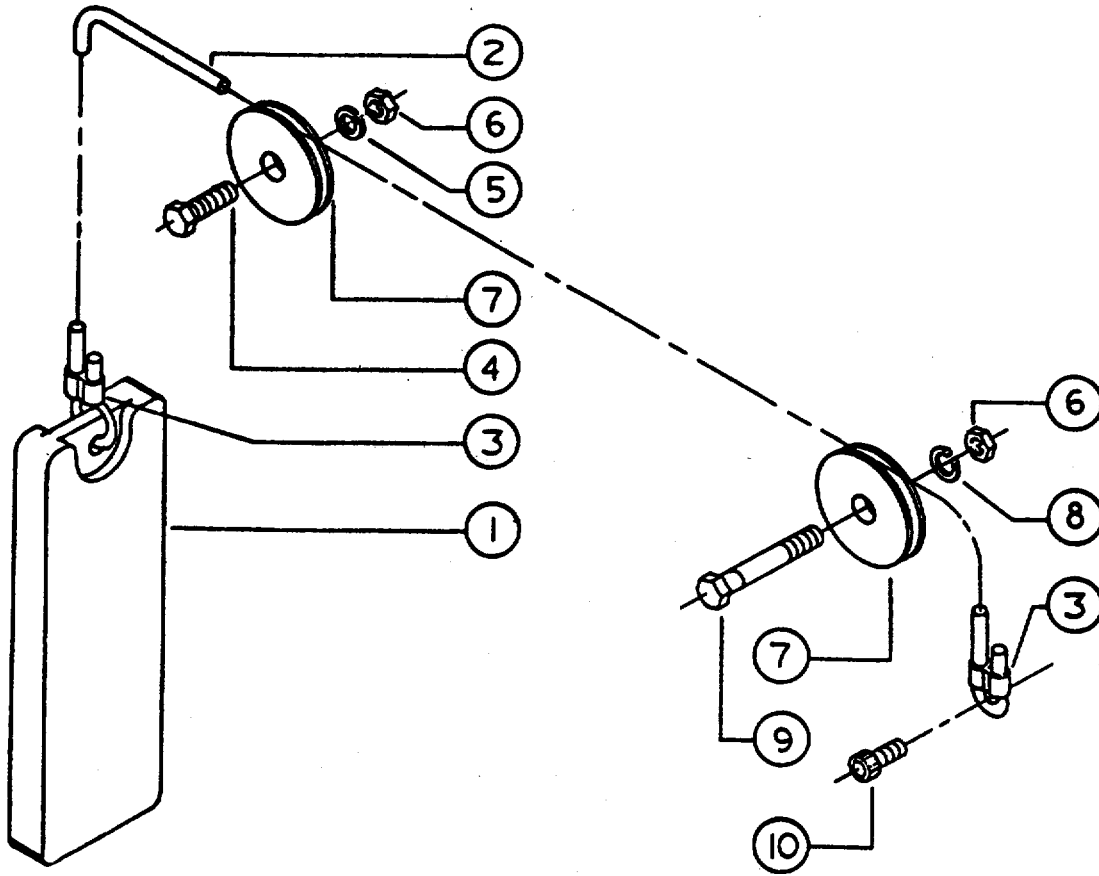

Figure 17. Counterweight Assembly (Standard).

COUNTERWEIGHT ASSEMBLY PARTS LIST

ITEM NO.	PART NO.	DESCRIPTION	QTY
	2103001	Counterweight Assy. (Items 1 thru 3)	
1	3044042	Bar, Balance Weight	1
2	6102001	Cable, Aircraft, 1/16" Dia.	6'
3	6284104	Fitting, Cable, Oval Sleeve	2
4	6718009	Scr., Hex Hd. Cap, 1/2-13 x 1-1/4"	1
5	6861500	Washer, 1/2" Lock	1
6	6S18008	Nut, Hex Jam, 1/2-13	2
7	3673031	Roller, Guide Bar Weight	2
8	6670018	Ring, Retaining	1
9	3691035	Scr., Guide Bar Roller	1
10	6714015	Scr., Soc. Hd. Cap, 1/4-20 x 1/2"	1

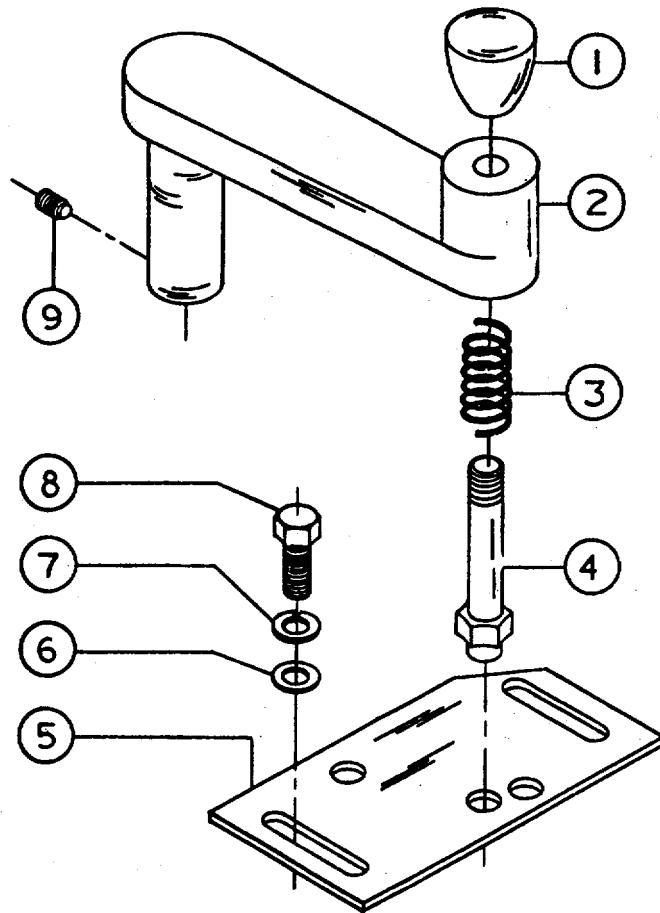

Figure 18. Transmission Shift Lever Assembly (Standard).

**TRANSMISSION SHIFT LEVER ASSEMBLY
PARTS LIST**

ITEM NO.	PART NO.	DESCRIPTION	QTY
	2426014	Lever, Shift Assembly (Items 1 thru 4)	
1	3406201	Knob	1
2	3426052	Lever, Shift	1
3	6813087	Spring, Compression	1
4	3582093	Pin, Shift Locking	1
5	359S333	Plate, Shift Detent	1
6	6861101	Washer, 1/4" Flat	2
7	6861100	Washer, 1/4" Lock	2
8	6714127	Scr., Hex Hd. Cap, 1/4-20 x 1/2"	2
9	6714004	Scr., Soc. Hd. Set, 1/4-20 x 1/4"	2

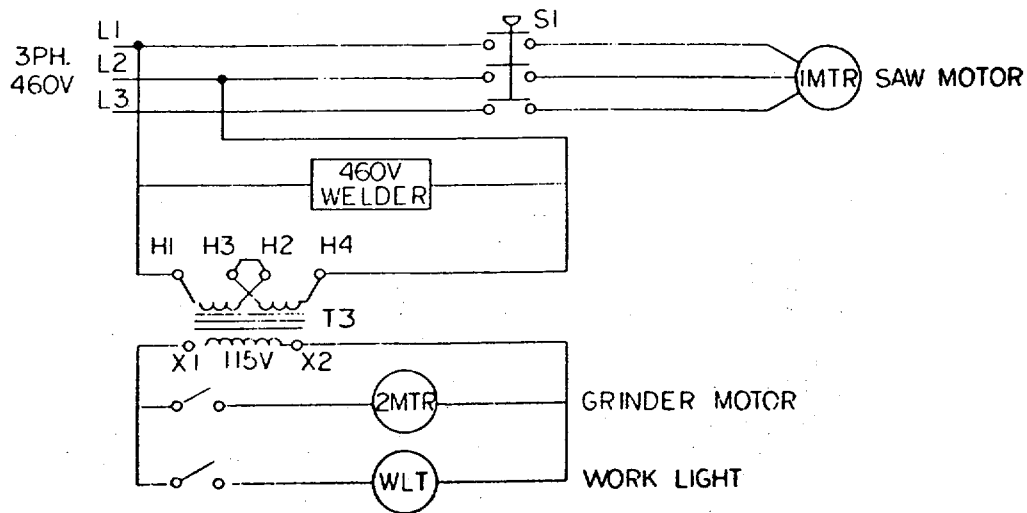
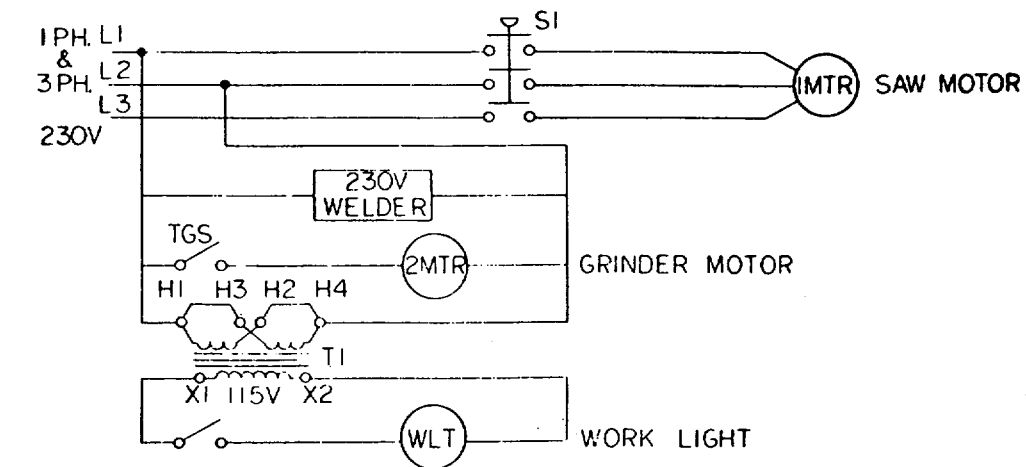
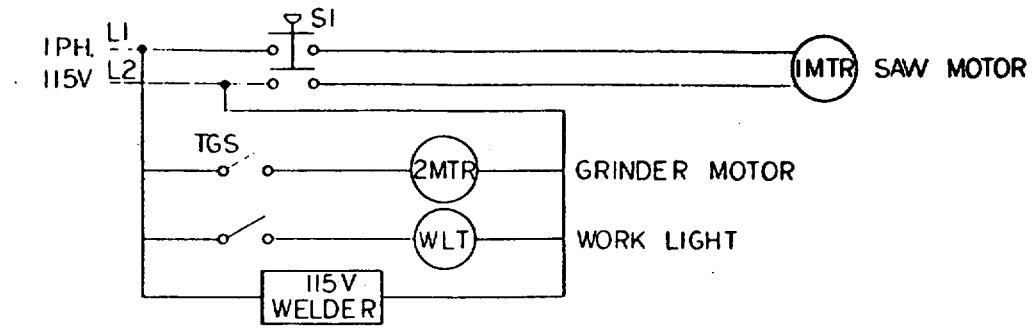

Figure 19. Electrical Schematic, Manual Control.

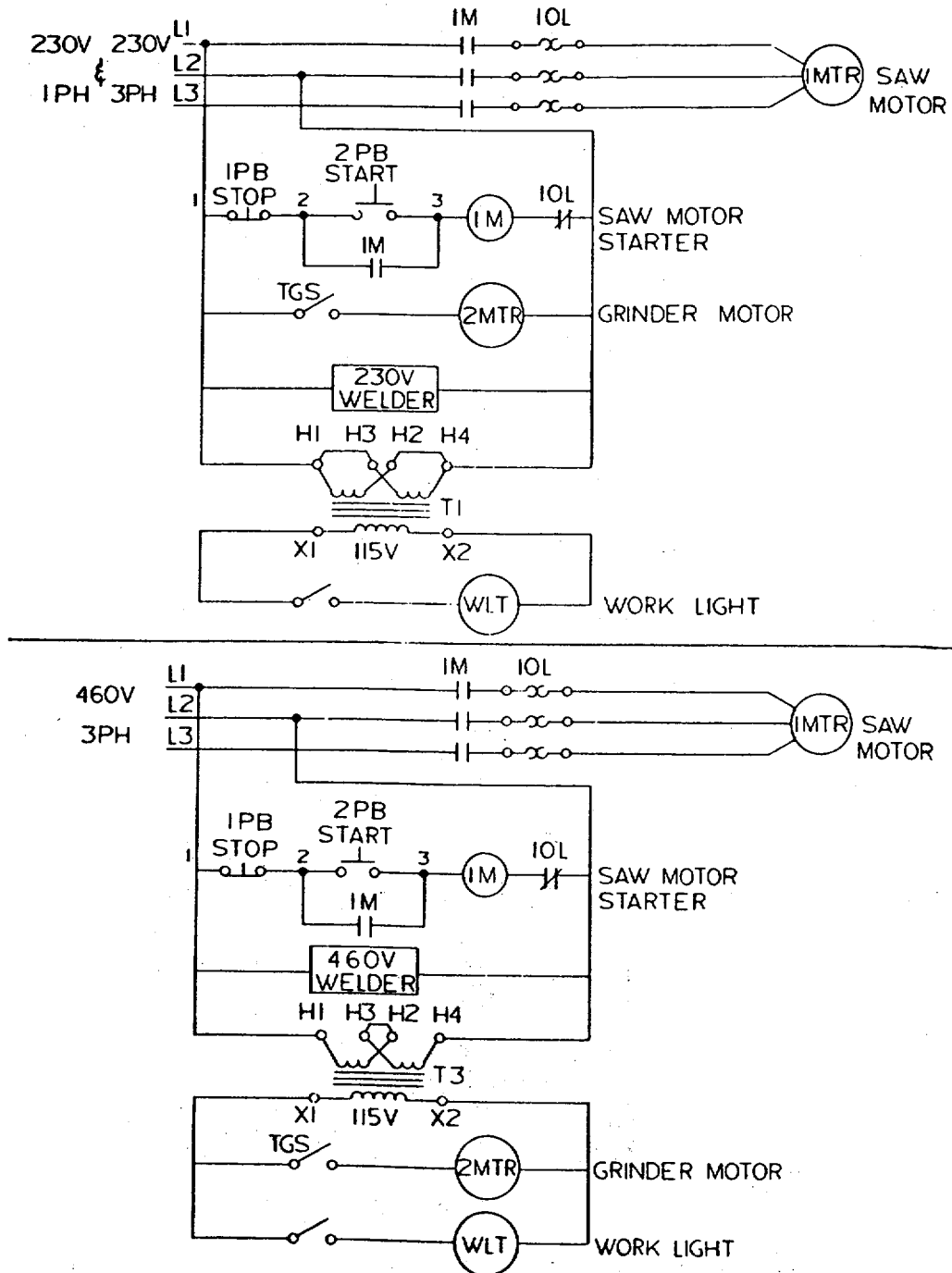

Figure 20. Electrical Schematic, Magnetic Control.

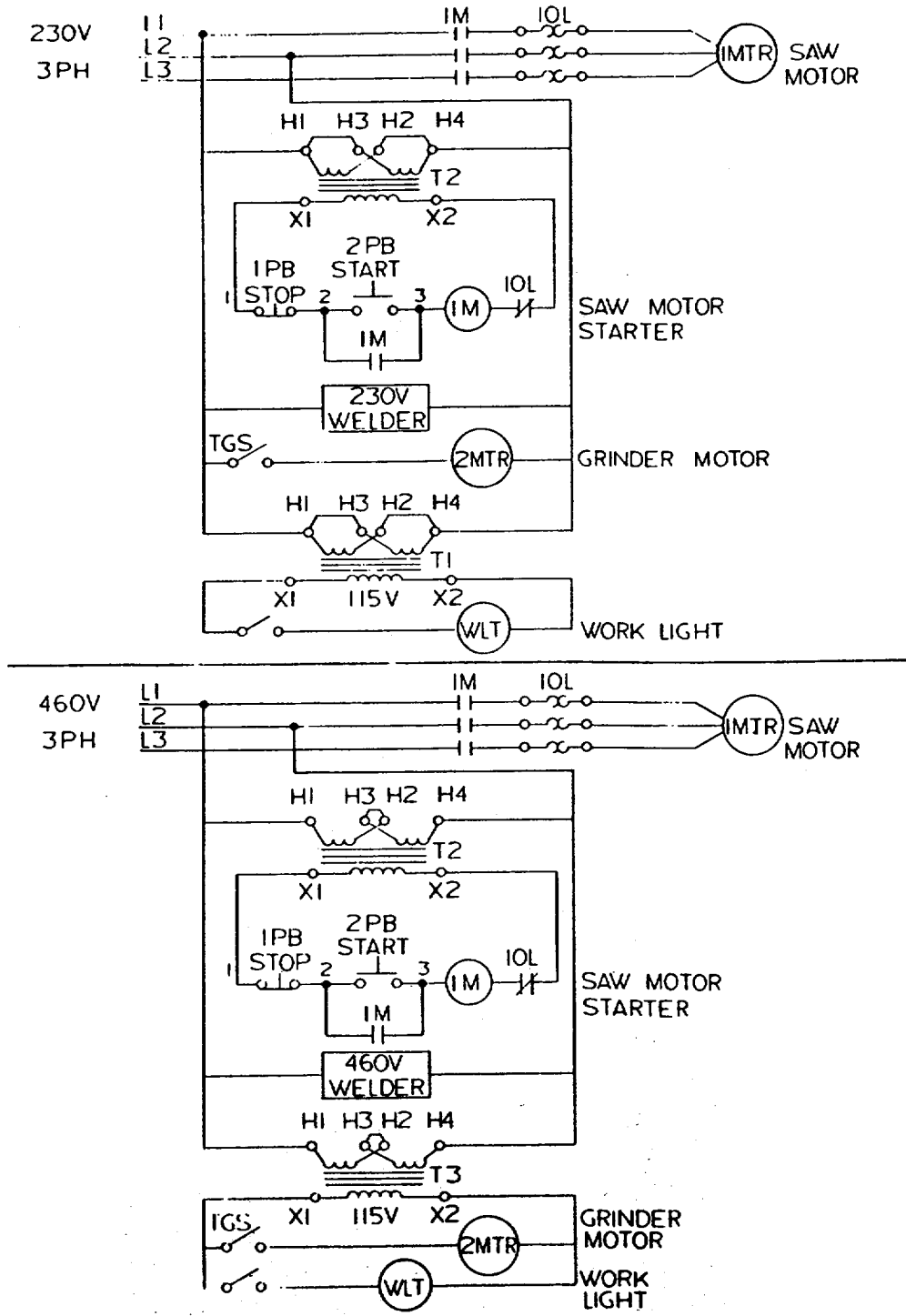

Figure 21. Electrical Schematic Magnetics with Low Voltage Control.

REF.	QTY.	NO.	DESCRIPTION
S1	1	(3PH)	SWITCH,
		(1PH)	SWITCH,
IPB	1		SWITCH,
2PB			
2MTR	1		MOTOR, ELEC, 1/8 HP, 1PH, 3600RPM, 115/230V
TGS	1		SWITCH, TOGGLE,
WLT	1		LIGHT, WORK,
T1	1		TRANSFORMER, 230/460-115V, 100VA
T3			TRANSFORMER, 230/460-115V, 500VA
T2	1		TRANSFORMER, 115/230-24V, 50VA
			TRANSFORMER, 230/460-24V, 75VA
			TRANSFORMER, 230/460-115V, 50VA
IM	1	(1PH)	STARTER, MAG.,
		(3PH)	STARTER, MAG.,
IM. WITH XMR	1		STARTER, MAG. W/XMR, 1PH, 24V,
			" " " 1PH, 115V,
			" " " 3PH, 24V,
			" " " 3PH, 115V,
WEL- DER	1		WELDER, , 115 V
			" " 230V
			" " 460V

Figure 22. Electrical Schematics Parts List.

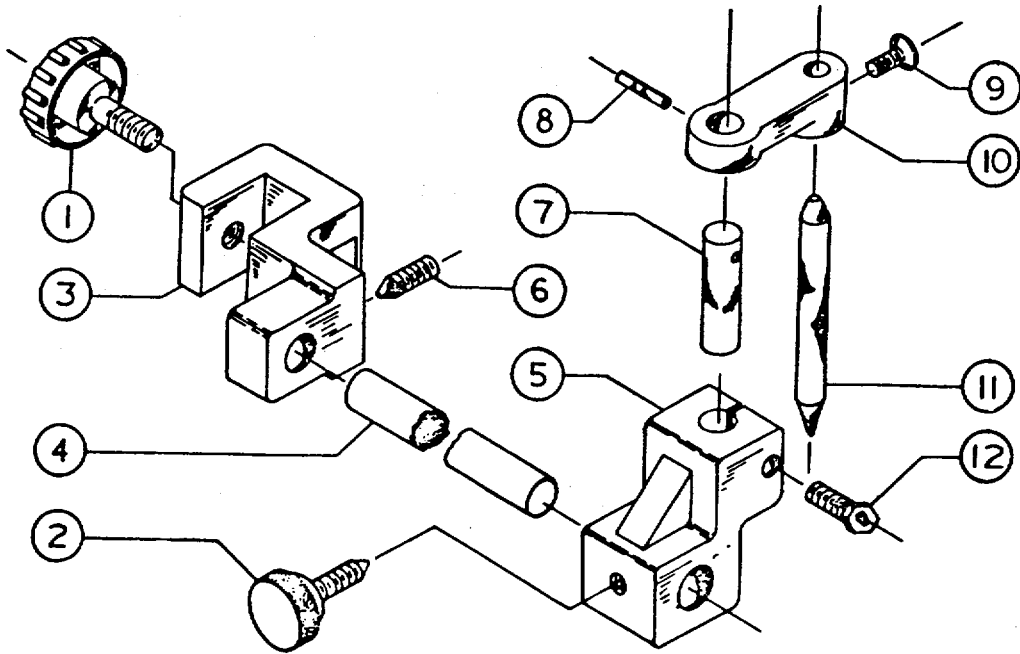

Figure 23. Circle Cutting Attachment (Optional).

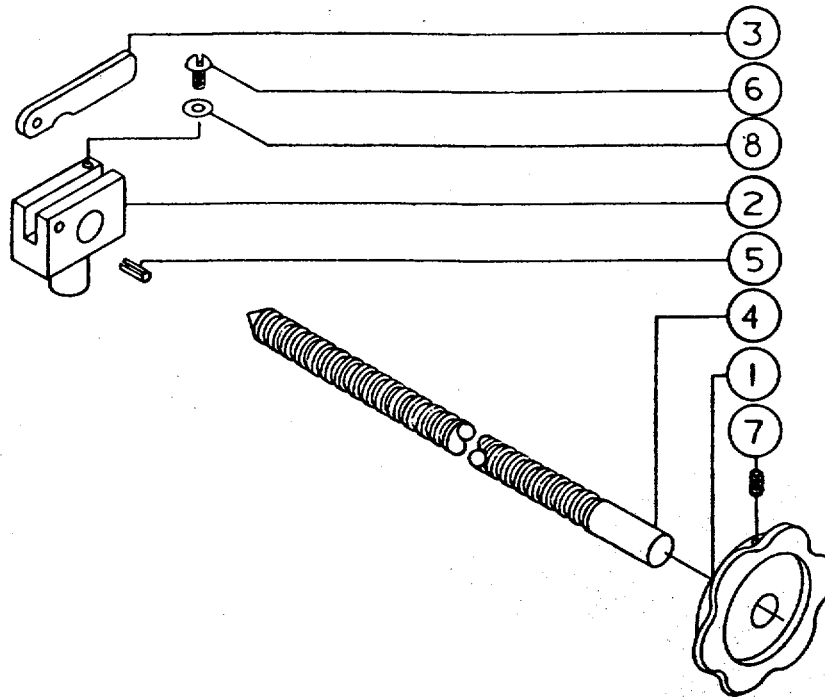

Figure 24. Hand Feed Assembly (Optional).

**HAND FEED ASSEMBLY
PARTS LIST**

ITEM NO.	PART NO.	DESCRIPTION	QTY
1	3271009	Handwheel, 3-1/2 x .627"	1
2	3529001	Nut, Hand Feed Screw, 3/4 x 1-1/4 x 3-3/4"	1
3	3581003	Pawl, Hand Feed Nut, .050 x 5/8 x 1-7/8"	1
4	3692002	Screw, Hand Feed, 518 x 13-3/4"	1
S	6626004	Pin, Spring, 1/8 x 3/4" L	1
6	6706035	Screw, Round Hd., 6-32 x 1/4" L	1
7	6715016	Screw, Soc. Set, Cup, 5/16-18 x 5/16" L	1
8	6860600	Washer, Steel, Flat, No. 6	1

**CIRCLE CUTTING ATTACHMENT
PARTS LIST**

ITEM NO.	PART NO.	DESCRIPTION	QTY
1	2406002	Knob Assembly	1
2	2406004	Knob Assembly	1
3	3064054	Bracket, Clamp	1
4	3044016	Bar, Guide	1
5	3064056	Bracket, Adjusting	1
6	6716117	Screw, Slot Hd., Cone Pt., 3/8-16 x 1 1/2"	1
7	3583002	Pin, Locating Pivot	1
8	6626032	Pin, Spring, 3/16 x 1-1/4 x 3/4" L	1
9	6715106	Screw, Thumb, 5/16-18 x 3/4" L	1
10	3289006	Holder	1
11	3604007	Pointer	1
12	6715034	-Scr., Hex Hd. Cap, 5/16-18 x 1-1/4" L	1

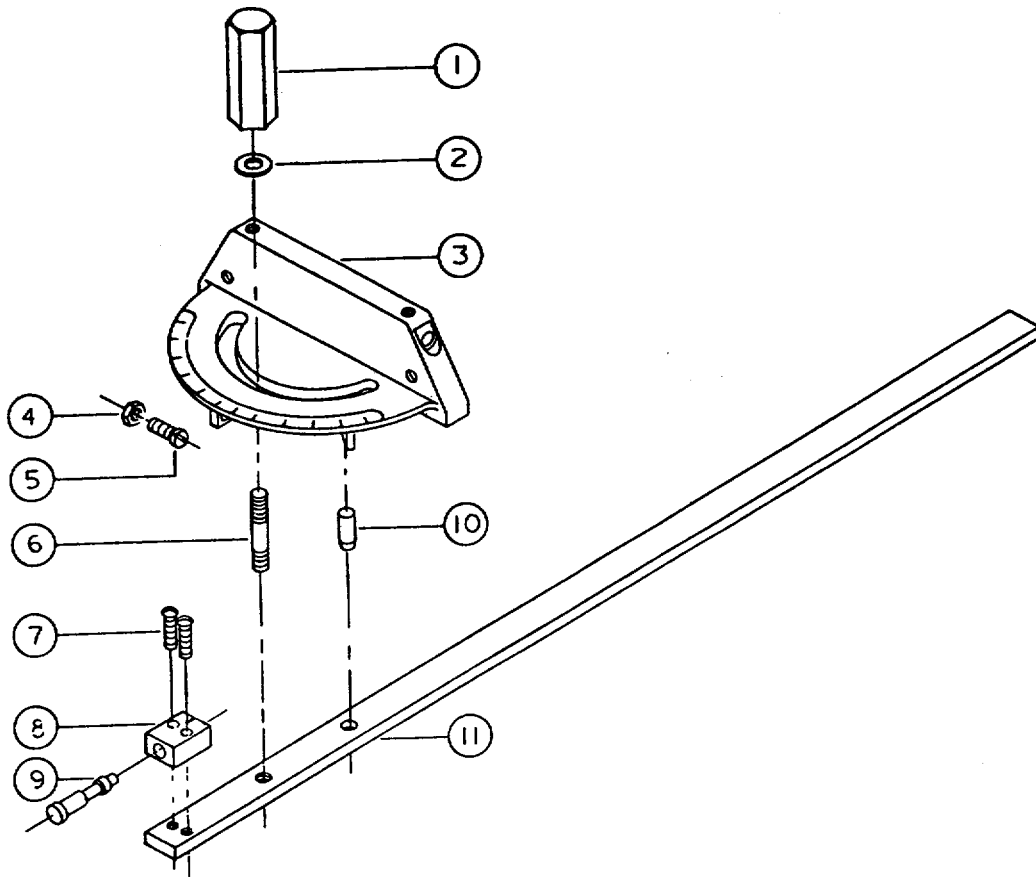

Figure 25. Miter Gage Assembly (Optional).

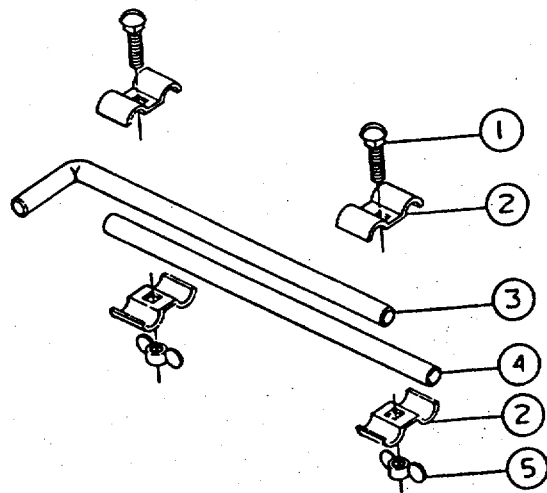

Figure 26. Stop Rod Assembly (Optional).

**MITER GAGE ASSEMBLY
PARTS LIST**

ITEM NO.	PART NO.	DESCRIPTION	QTY
1	3268050	Knob, Miter	1
2	6861101	Washer, Flat, 1/4"	1
3	3230007	Gage Miter	1
4	6506003	Nut, Hex, No. 6-32 (Plated)	3
S	6706094	Scr., Rd. Hd. Mach., No. 6-32 x 1/2"	3
6	3695220	Screw, Lock	1
7	6706041	Scr., Rd. Hd. Mach., 6-32 x 3/4"	2
8	3055101	Block, Pointer	1
9	3582097	Pin, Stop	1
10	6623012	Pin, Dowel, 114 x 1"	1
11	3044312	Bar, Miter, Gage	1

**STOP ROD ASSEMBLY
PARTS LIST**

ITEM NO.	PART NO.	DESCRIPTION	QTY
1	6086000	Bolt, Carriage, No. 10-24 x 3/4"	2
2	3092001	Clamp	4
3	3670002	Rod, Stop (900 Bend)	1
4	3670003	Rod, Stop (Straight)	1
5	6510002	Nut, Wing, No. 10-24 (Zinc Plated)	1

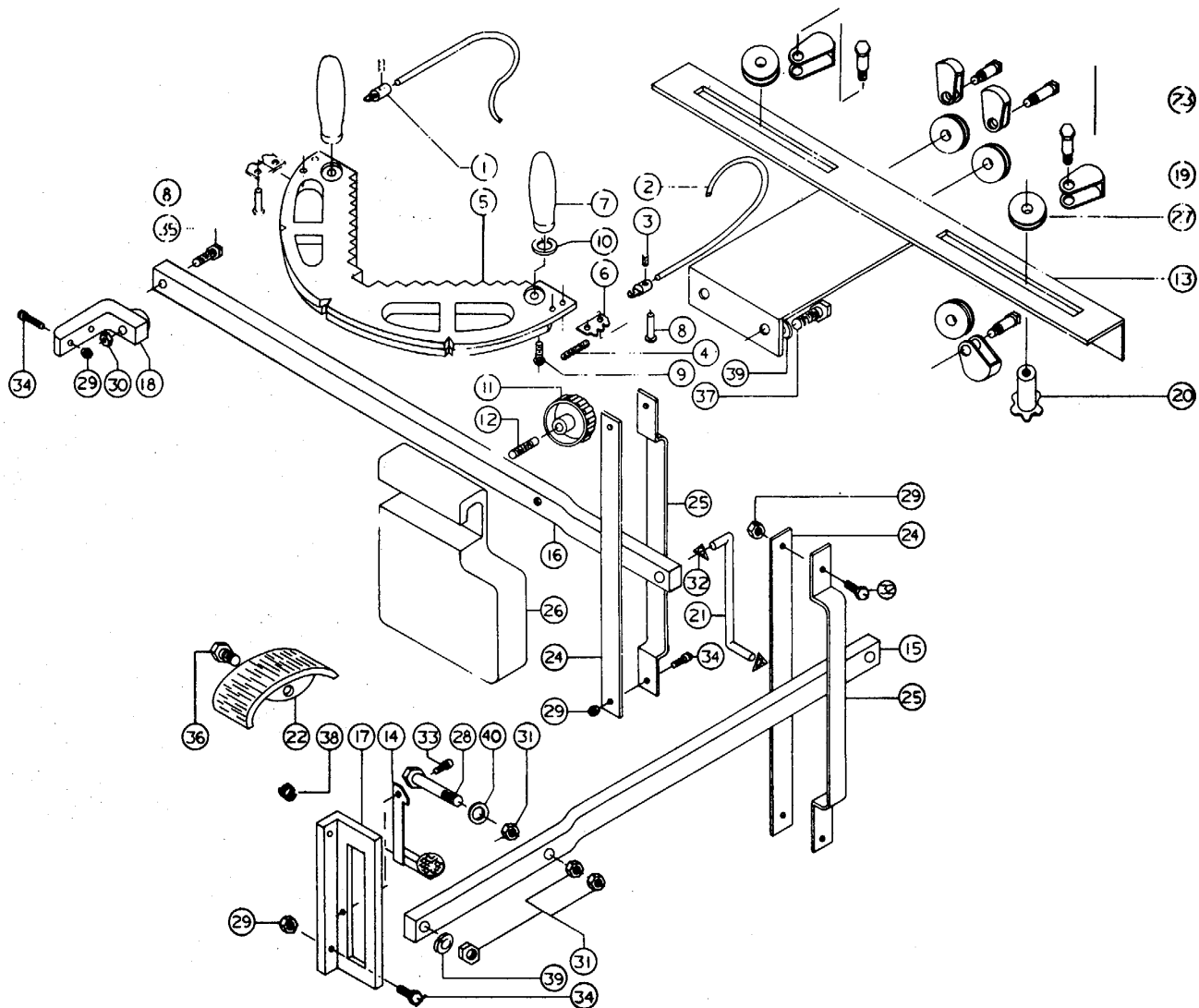

Figure 27. Power Feed Attachment (Optional).

**POWER FEED ATTACHMENT
PARTS LIST**

ITEM NO.	PART NO.	DESCRIPTION	QT Y
	2253026	Guide Assy., Material (Items 1Thru 10)	
	2077001	Cable Assy., Mat. Guide Long (Items 1 Thru 3)	
1	3295001	Hook, Chain	2
2	3077003	Cable, Aircraft 1/8" Dia. x 8' L	1
3	6714004	Scr., Soc. Set, Cup Pt., 1/4-20 x 114" L	2
4	3083022	Chain, Roller, No. 65-1-1/2P 48" L	1
5	3253030	Guide, Material	1
6	3688001	Segment, Tooth	2
7	6350007	Handle	2
8	6680008	Rivet, Flat Hd., 3/16 x 5/8" L	4
9	6765010	Screw, Button Hd. Cap, 5/16-24 x 3/4" L	2
10	6861200	Washer, 5/16" Lock	2
	2695002	Screw, Lock Assy. (Items 11 & 12)	
11	3406017	Knob	1
12	3695019	Screw, Lock	1
13	2063002	Brkt. Assy., Powerfeed (Weldment)	1
14	2587001	Lock Assy., Pedal (Weldment)	1
15	3044038	Bar, Pedal	1
16	3044060	Bar, Weight	1
17	3062005	Bracket, Angle	1
18	3065003	Bracket, Pivot	1
19	3250009	Guard, Wheel	5
20	3406025	Knob, Powerfeed	2
21	3445004	Link, Connecting	1
22	3587002	Pedal, Foot	1
23	3697202	Screw, Shoulder	5
24	3770013	Strip, Guide	2
25	3770014	Strip, Guide	2
26	3848008	Weight	1
27	3850001	Wheel, Powerfeed	5
28	6086022	Bolt, Tap 1/2-13 x 2-3/4" L	1
29	6514001	Nut, Hex 1/4-20	9
30	6516001	Nut, Hex 3/8-16	1
31	6518001	Nut, Hex 1/2-13	4
32	6670078	Ring, Retaining,	2
33	6714040	Scr., Fil. Hd., 1/4-- 20 x 1-1/2" L	2
34	6714048	Scr., Hex Hd. Cap, 1/4 --20 x 1" L	7
35	6716037	Scr., Hex Hd. Cap, 3/8-16 x 2" L	1
36	6718012	Scr., Hex Hd. Cap, 1/2-13 x 2" L	1
37	6718015	Scr., Hex Hd. Cap, 1/2-13 x 1" L	2
38	6813002	Spring, Compression,	1
39	6861500	Washer, 1/2" Lock Spring	3
40	6861501	Washer, 1/2" Flat	1

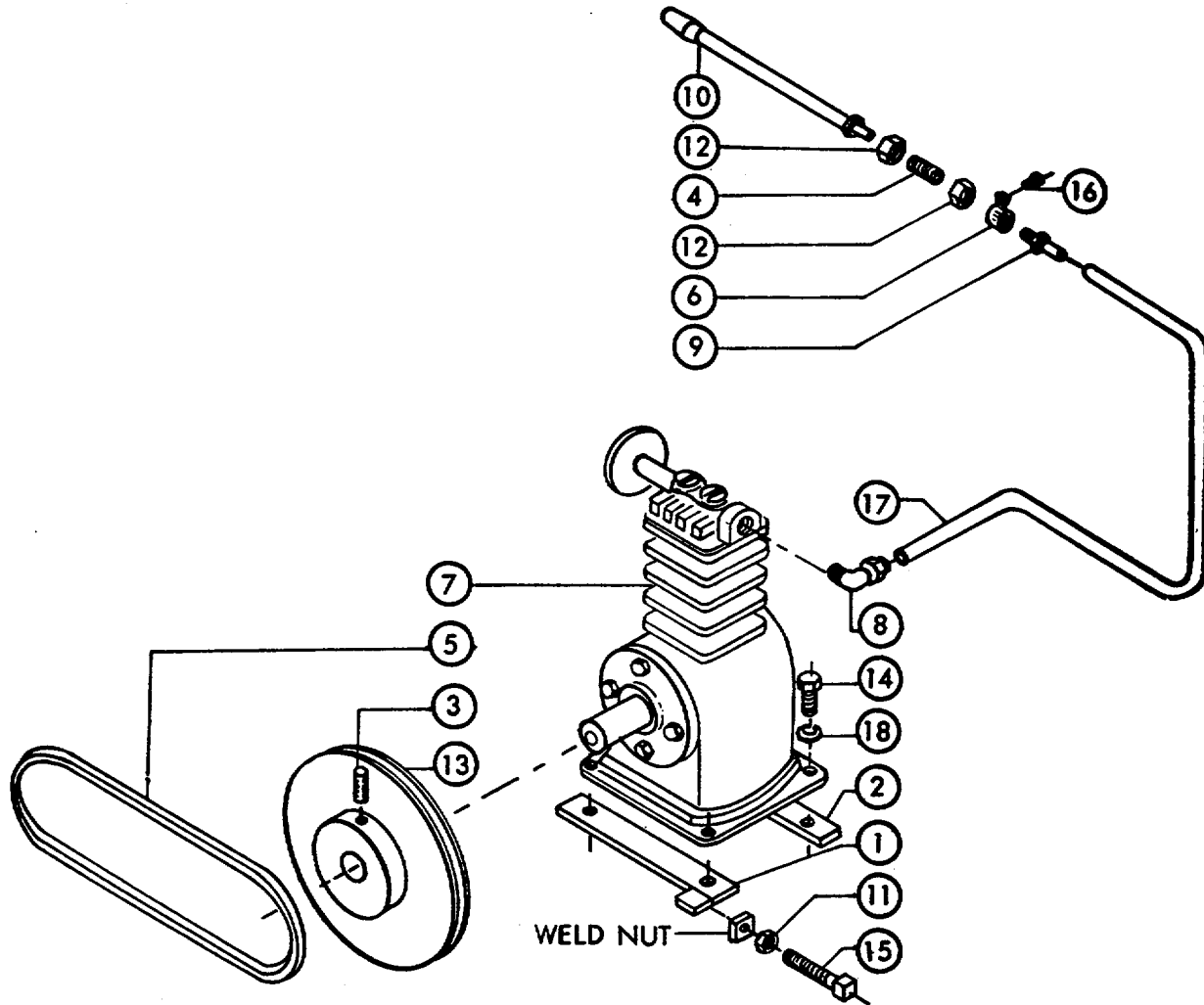
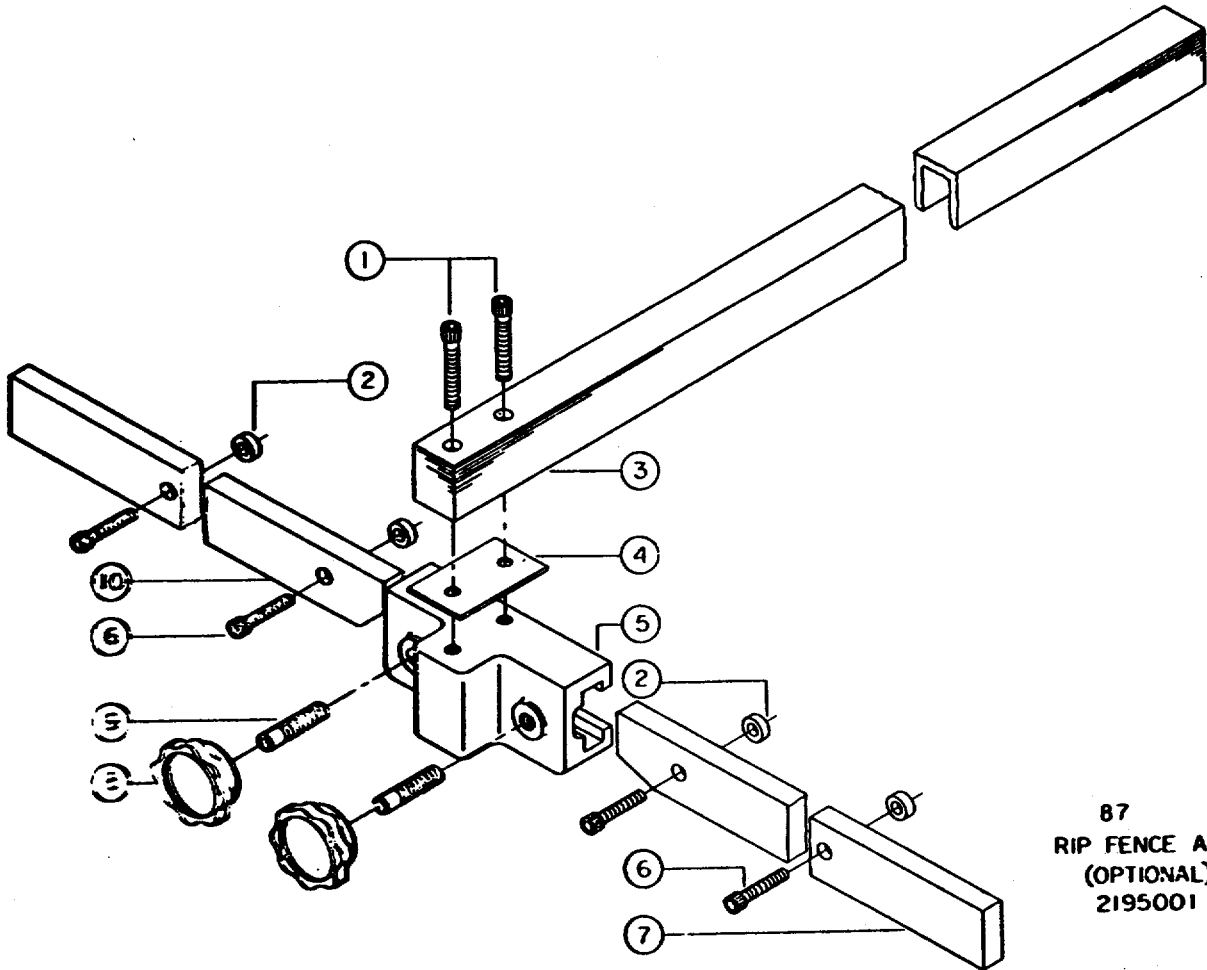

Figure 28. Chip Blower Kit (Optional).

**CHIP BLOWER KIT
PARTS LIST**

ITEM NO.	PART NO.	DESCRIPTION	QTY
1	2040036	Bar, Compressor Mounting Assembly	1
2	3044309	Bar, Compressor Mounting	1
3	3716035	Sheave, Compressor	1
4	3773216	Stud, Mounting	1
5	6077076	Belt, "V" 7M710	1
6	6122023	Clamp, Tube, 3/8"	1
7	6134001	Compressor,	1
8	6284064	Fitting, Tube, No. KF04-04PS-900	1
9	6284073	Fitting, Tube, 1/4 I.D. Tube x 1/8 NPT No. MBS 300-1/8 x 27	1
10	6498001	Nozzle, 1/8-27 NPT	1
11	6515007	Nut, Hex Jam, 5/16-18 (Belt Adj.)	1
12	6519004	Nut, Hex Jam, 9/16-12	2
13	6714000	Scr., Soc. Hd. Set, 1/4-20 x 1/2" L	1
14	6715032	Scr., Hex Hd. Cap, 5/16-18 x.1" L	4
15	6715092	Scr., Soc. Hd. Set, 5/16-18 x 1-3/4" L (Belt Adjust.)	1
16	6746002	Scr., Pan Hd. Self Tapping, No.8 x 3/8" L	1
17	6833009	Tube, Black Plastic, 3/8 O.D. x .075 Wall	8
18	6861200	Washer, Lock 5/16"	4



87
RIP FENCE ASSY
(OPTIONAL)
2195001

Figure 29. Rip Fence Assembly (Optional).

**RIP FENCE ASSEMBLY
PARTS LIST**

ITEM NO.	PART NO.	DESCRIPTION	QTY
1	6716014	Scr., Soc. Hd. Cap, 318-16 x 2-1/2"	2
3	3735001	Spacer, Fence Bar	4
3	3195002	Fence, Rip	1
4	3722004	Shim, Rip Fence	1
S	3063046	Bracket, Rip Fence Mounting	1
6	6715020	Scr., Soc. Hd. Cap, 5/16-18 x 1"	4
7	3044041	Bar, Right Hand Fence	1
8	3406017	Knob	2
9	3695032	Screw, Lock	1
10	3044040	Bar, Left Hand Fence	1

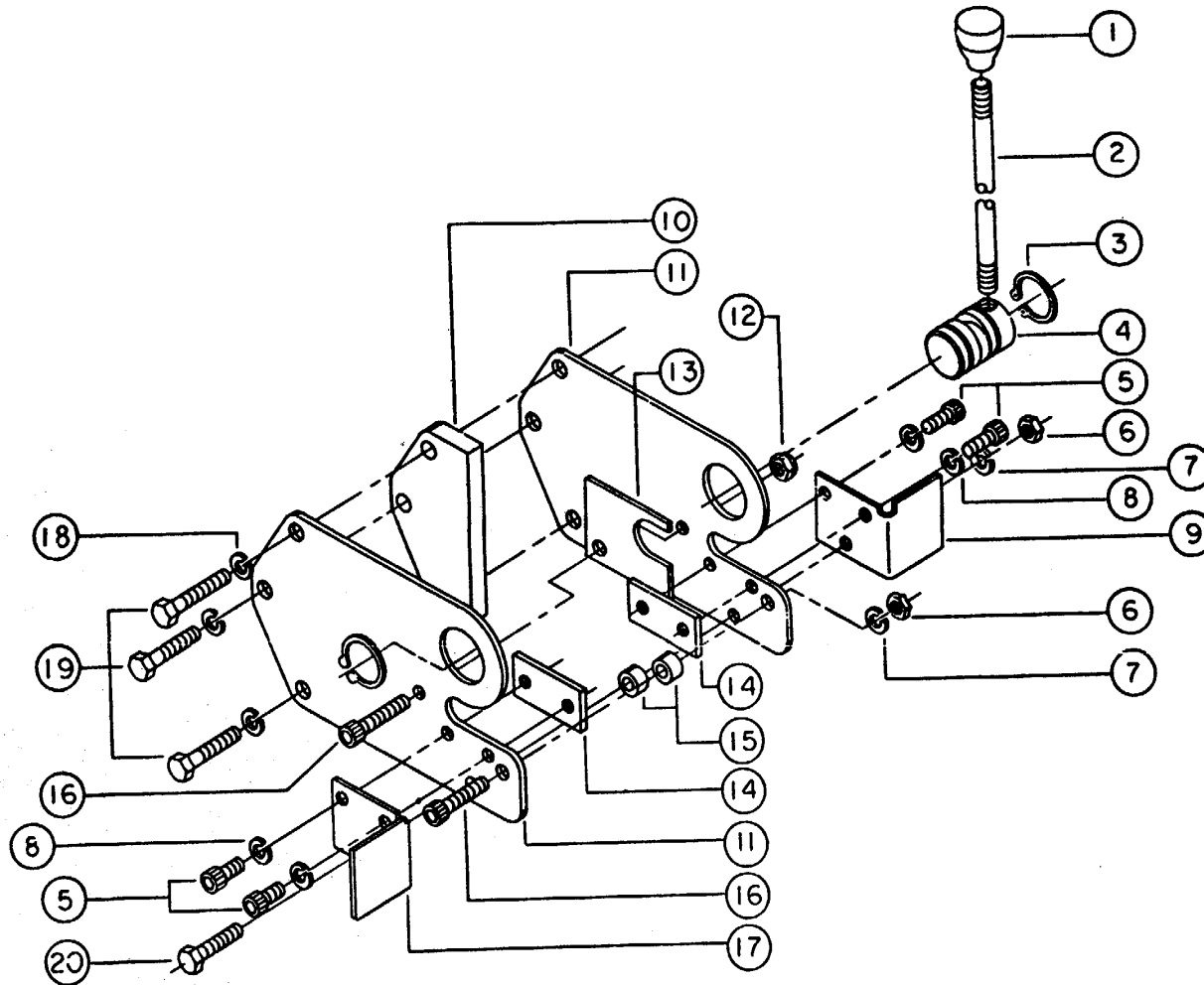

Figure 30. Blade Cutter Assembly (Optional).

**BLADE CUTTER ASSEMBLY
PARTS LIST**

ITEM NO.	PART NO.	DESCRIPTION	QTY
1	3407201	Knob, Teardrop	1
2	3670030	Rod, Cam Operating, Blade Cutter	1
3	6670005	Ring, Retaining,	2
4	3076004	Cam, Blade Cutter	1
5	6710014	Scr., Soc. Hd. Cap, No. 20-24 x 3/8"	4
6	6514008	Nut, Hex lam, 1/4-20	2
7	6861100	Washer, 1/4" Lock	2
8	6860802	Washer, No. 10 Lock	4
9	3215004	Flange, Blade Cutter, Right Hand	1
10	3042008	Base, Blade Cutter Spacing	1
11	3595015	Plate, Side	2
12	6514002	Nut, Hex Lock, 1/4-20	1
13	3052001	Blade, Cutter, Sliding	1
14	3052002	Blade, Cutter, Stationary	2
15	3735014	Spacer, Inside, Blade Cutter	2
16	6714016	Scr., Soc. Hd. Cap, 1/4-20 x 1"	2
17	3215001	Flange, Blade Cutter, Left Hand	2
18	6861200	Washer, 5/16" Lock	3
19	6715034	Scr., Hex Hd. Cap, 5/16-18 x 1-1/4"	3
20	6714048	Scr., Hex Hd. Cap, 1/4-20 x 1"	1

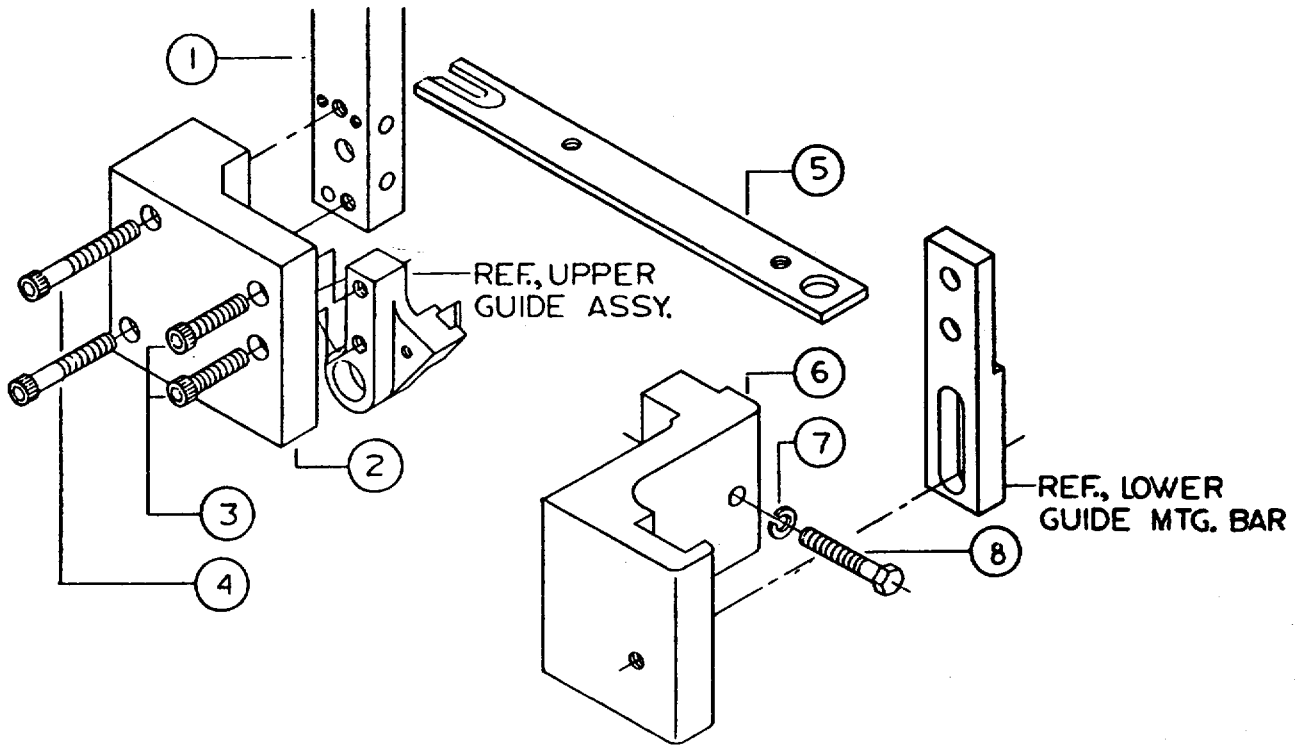

Figure 31. Guide Assembly, 900 (Optional).

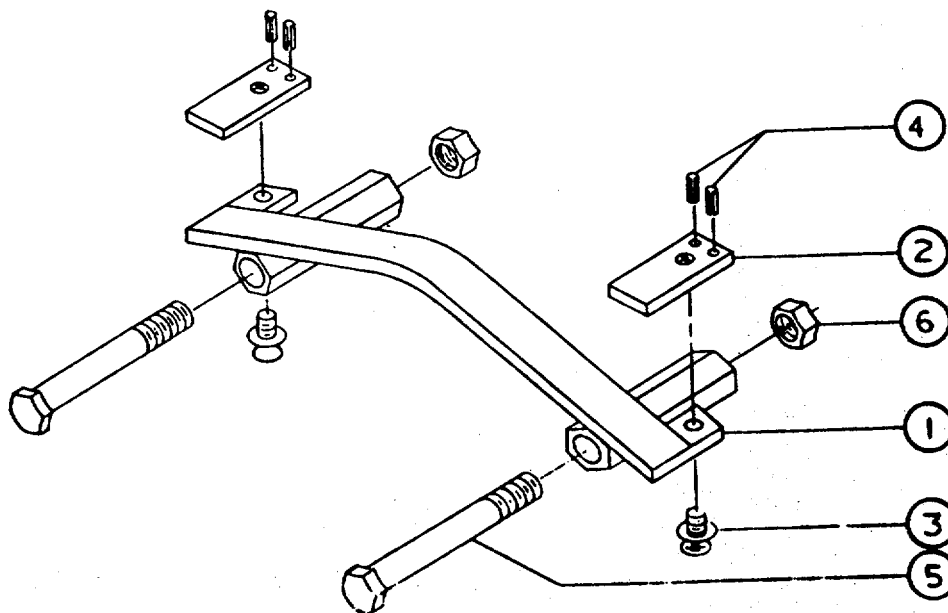

Figure 32. Clamp Assembly Blade Filing (Optional).

**GUIDE ASSEMBLY, 90°
PARTS LIST**

ITEM NO.	PART NO.	DESCRIPTION	QTY
1	3044211	Bar, Guide, 90° Twist	1
2	3062031	Bracket, Upper Guide Mtg., 90° Twist	1
3	6716012	Scr., Soc. Hd. Cap, 3/8-16 x 1"	2
4	6716024	Scr., Soc. Hd. Cap, 3/8-16 x 2-1/4"	2
5	3328063	Insert, Table, 90° Twist	1
6	3062033	Bracket, Lower Guide Mtg., 90° Twist	1
7	6861300	Washer, 3/8" Lock	1
8	6716124	Scr., Hex Hd. Cap, 3/8-16 x 2-1/4"	1

**CLAMP ASSEMBLY BLADE FILING
PARTS LIST**

ITEM NO.	PART NO.	DESCRIPTION	QTY
1	2042003	Base Assy., Mounting Post (Weldment)	1
2	3092014	Clamp, Saw Blade	2
3	6715066	Screw, Thumb	2
4	6626002	Pin, Spring, 1/8 x 3/8"	4
5	6716149	Scr., Hex Hd. Cap, 3/8-16 x 3-1/2"	2
6	6516001	Nut, Hex, 3/8-16	2

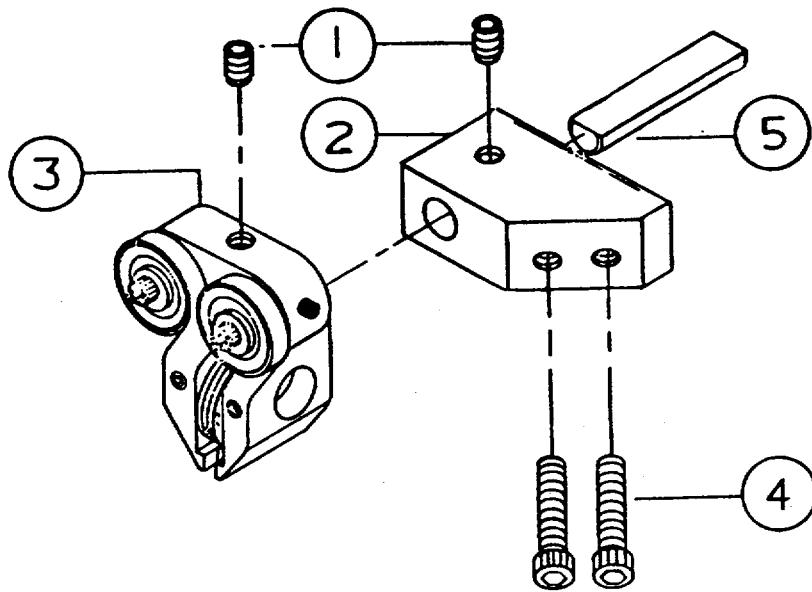

UPPER 45° TWIST ASSY.

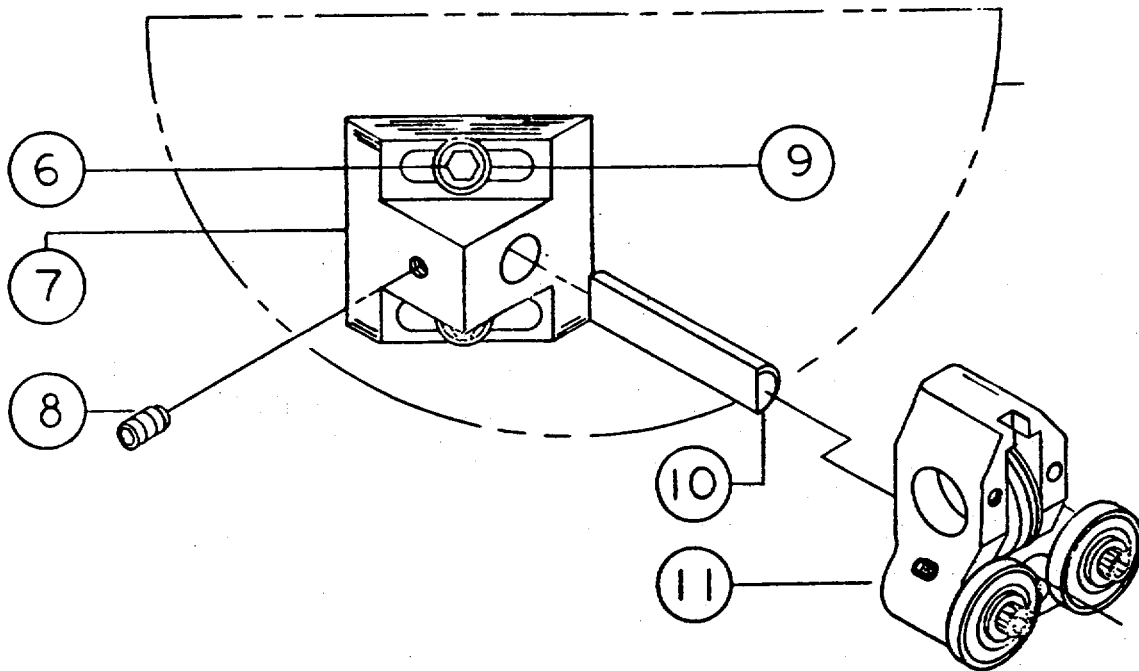

LOWER 45° TWIST ASSY.

Figure 33. 45° Twist Guide Assembly (Optional).

**45° TWIST GUIDE ASSEMBLY
PARTS LIST**

ITEM NO.	PART NO.	DESCRIPTION	QTY
	2253049	Guide Assembly, 45° Upper (Items 1 Thru 5)	
1	6714159	Scr., Soc. Set, 1/4-20 x 3/8"	2
2	3064211	Bracket, Upper Guide Mounting	1
3	6339002	Guide, Band Saw	1
4	6715027	Scr., Soc. Hd. Cap, 5/16-18 x 1-3/4"	2
5	3582028	Pin, Dowel, 7/16 x 2-1/2"	1
	2253054	Guide Assembly, 45° Lower (Items 6 Thru 11)	
6	6715020	Scr., Soc. Hd. Cap, 5/16--18 x 1"	2
7	3064212	Bracket, Lower Guide Mounting	1
8	6714159	Scr., Soc. Set, 1/4-20 x 3/8"	2
9	6861201	Washer, 5/16" Flat	2
10	3582027	Pin, Dowel, 7/16 x 2-5/8"	1
11	6339002	Guide, Band Saw	1

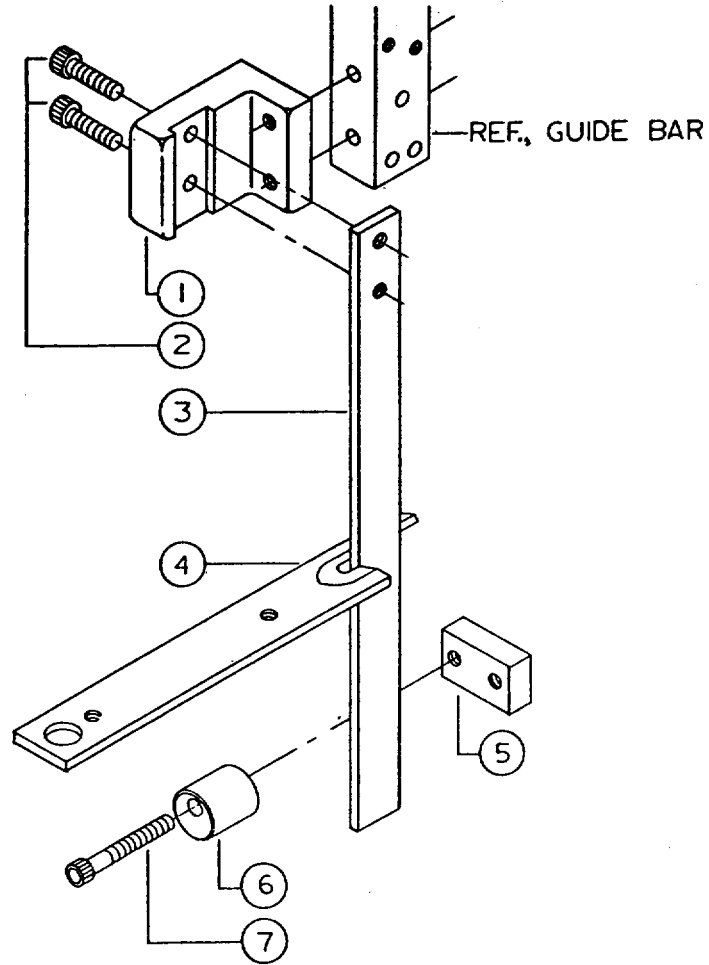

Figure 34. Band Polishing Attachment (Optional).

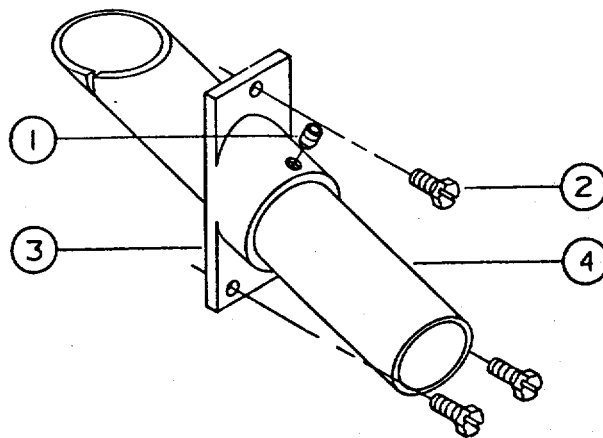

Figure 35. Dust Chute Assembly (Optional).

**BAND POLISHING ATTACHMENT
PARTS LIST**

ITEM NO.	PART NO.	DESCRIPTION	QTY
1	3064280	Bracket, Upper Polishing Guide	1
2	6710016	Scr., Soc. Hd. Cap, 10-24 x 5/8"	2
3	3595288	Plate, Backup	1
4	3328064	Insert, Band Saw Table	1
5	3063426	Bracket, Lower Polishing	1
6	3157005	Eccentric, Band Polishing Att.	1
7	6716019	Scr., Soc. Hd. Cap, 3/8-16 x 2"	1
	2028063	Complete Band Polishing Att. Consists of 1 each of Above Parts	

**DUST CHUTE ASSEMBLY
PARTS LIST**

ITEM NO.	PART NO.	DESCRIPTION	QTY
1	6714004	Scr., Soc. Set, Cup Pt., 1/4-20 x 5/8"	1
2	674603	Scr., Hex Slotted Hd., Self- Tapping, 10-24 x 5/8"	3
3	3064314	Bracket, Exhaust Mounting	1
4	3589031	Pipe Exhaust	1
5	0340030	Drawing for Dust Chute Assembly Mounting	1
	2397031	Complete Dust Chute Assembly Consists of 1 each of Above Parts	

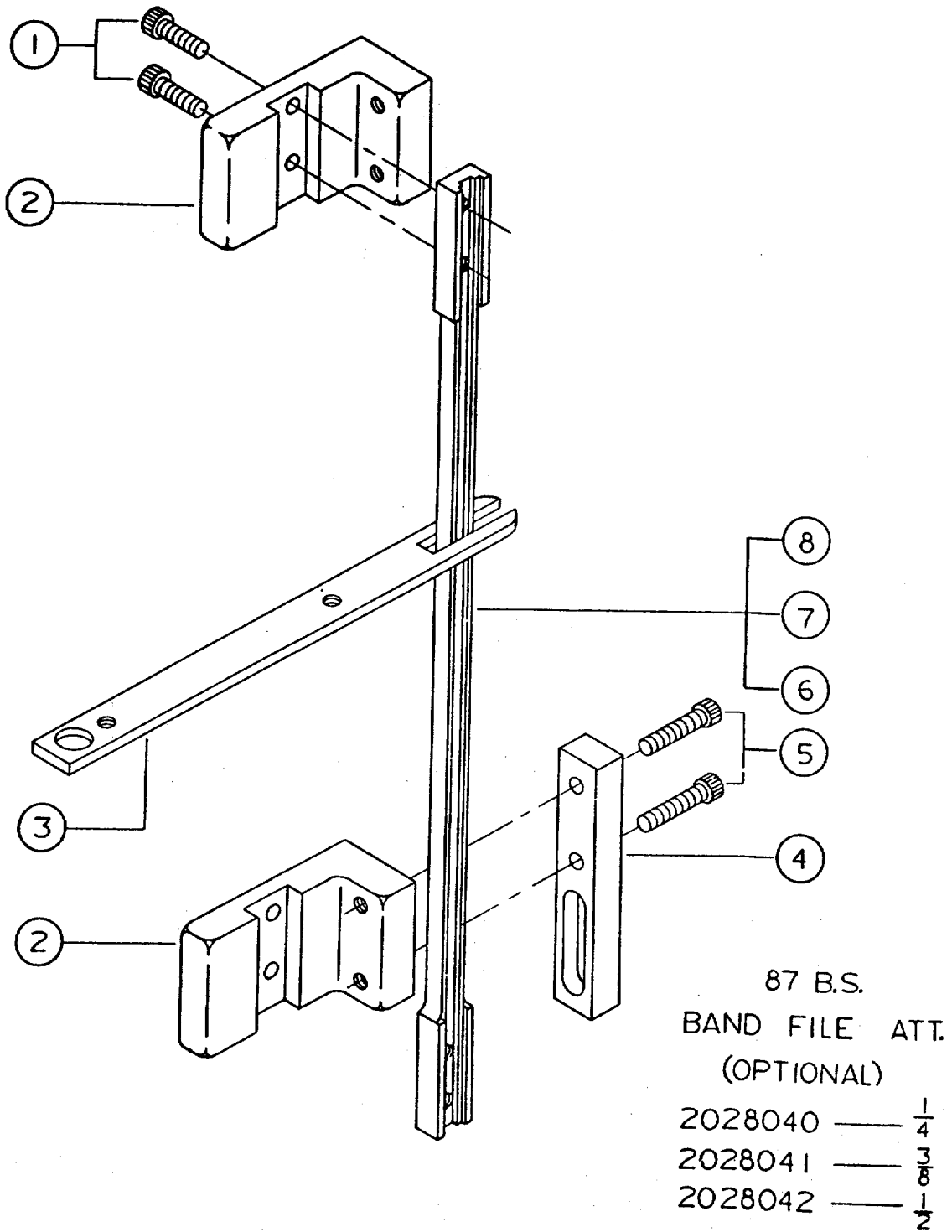

Figure 36. Band File Attachment (Optional).

**BAND FILE ATTACHMENT
PARTS LIST**

ITEM NO.	PART NO.	DESCRIPTION	QTY
1	6710016	Scr., Sec. Hd. Cap, 10-24 x 5/8"	2
2	3064282	Bracket, File Guide	2
3	3328054	Insert, Table Band Filing	1
4	3044204	Bar, File Att., Mounting	1
5	6716016	Scr., Soc. Hd. Cap, 3/8-16 x 7/8"	2
6	3253026	Guide, File, 1/4" Only	1
7	3253027	Guide, File, 3/8" Only	1
8	3253028	Guide, File, 1/2" Only	1
	2028040	Complete Band File Attachment Consists of Items 1, 2, 3, 4, 5, 6	
	2028041	Complete Band File Attachment Consists of Items 1, 2, 3, 4, 5, 7	
	2028042	Complete Band File Attachment Consists of Items 1, 2, 3, 4, 5, 8	

By Order of the Secretary of the Army:

Official:

E. C. MEYER
General, United States Army
Chief of Staff

J. C. PENNINGTON
Major General, United States Army
The Adjutant General

Distribution:

☆U.S. GOVERNMENT PRINTING OFFICE: 1994 0 - 300-421 (82407)

RECOMMENDED CHANGES TO EQUIPMENT TECHNICAL PUBLICATIONS



THEN...JOT DOWN THE DOPE ABOUT IT ON THIS FORM. CAREFULLY TEAR IT OUT, FOLD IT AND DROP IT IN THE MAIL.

SOMETHING WRONG WITH PUBLICATION

FROM: (PRINT YOUR UNIT'S COMPLETE ADDRESS)

DATE SENT

PUBLICATION NUMBER

PUBLICATION DATE

PUBLICATION TITLE

BE EXACT PIN-POINT WHERE IT IS

PAGE NO.

PARA-GRAPH

FIGURE NO.

TABLE NO.

IN THIS SPACE, TELL WHAT IS WRONG AND WHAT SHOULD BE DONE ABOUT IT.

TEAR ALONG PERFORATED LINE

PRINTED NAME, GRADE OR TITLE AND TELEPHONE NUMBER

SIGN HERE

